

Light & Design is  
the harmony of  
atmosphere and matter,  
the balance of emotion  
and function, the  
symbiosis of technology  
and delicacy

VIBIA

# Outdoor

Bamboo  
440

Palo Alto  
426

Break  
450

Plis  
Outdoor  
468

Brisa  
432

Plus  
456

Empty  
436

Scotch  
466

June  
459

Wind  
444

Meridiano  
470

Micro  
464

Origami  
422



# Origami

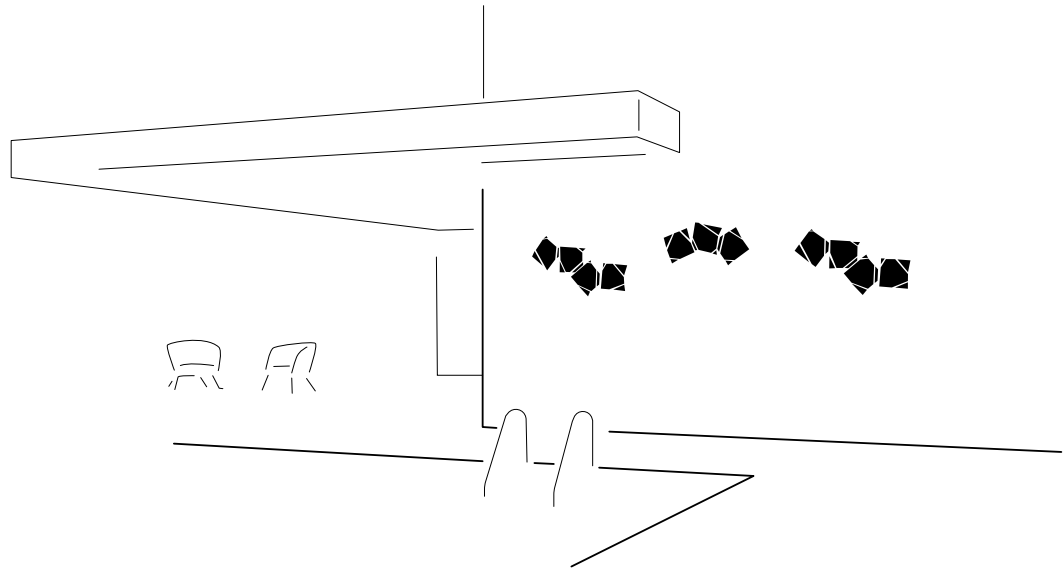
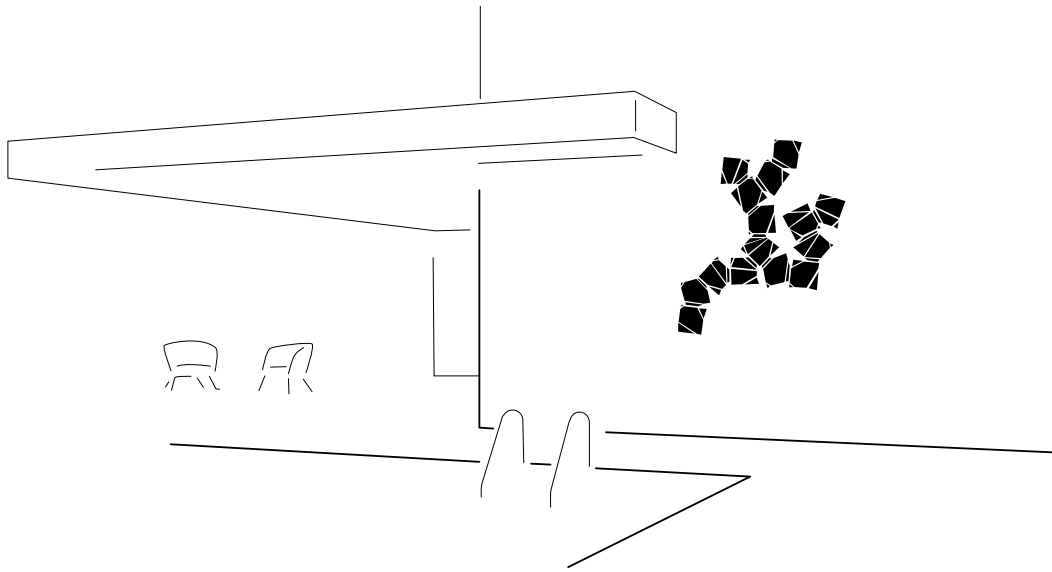

Design by Ramón Esteve.

Recalling the folded paper of the Japanese art form for which it's named, Origami generates a stunning play of light and shadows. Composed of two architectural modules that be arranged in countless personalized designs, it creates the effect of climbing ivy along a blank expanse of wall.



Recalling the folded paper of the Japanese art form for which it's named, Origami is composed of two architectural modules that be arranged in countless personalized designs. Positioning clusters across a broad surface creates the effect of climbing ivy along a blank expanse of wall and doubles as dramatic wall art. Powered by an LED and requiring only a single electrical outlet, Origami casts an ambient glow, generating a stunning play of light and shadows.

- 10 White (NCS S 0300-N)
- 29 Brown D1 (NCS S 8005-Y50R)
- 38 Terra dark (NCS S 5040-Y70R)
- 53 Green M1 (NCS S 6005-G80Y)

Cover: Polycarbonate.  
 Connecting arm: Polycarbonate.  
 Shade: ABS.  
 Diffuser: Polycarbonate.

LED 2700 K. CRI>80. 120 lm/W.  
 Dimming: TRIAC.

A maximum of 30 modules can be connected to a single connection point. For bigger compositions, check connection system.

#### Personalization options available

- Configuration layout at [vibia.com](http://vibia.com)
  - LED 3000 K / 4000 K
- Request more information.

4500

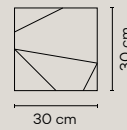

4501

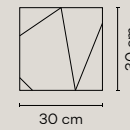

4504

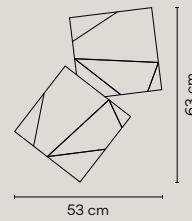

4506

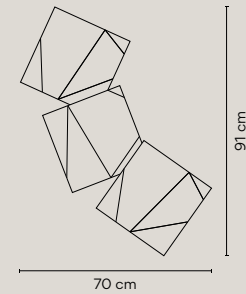

4508

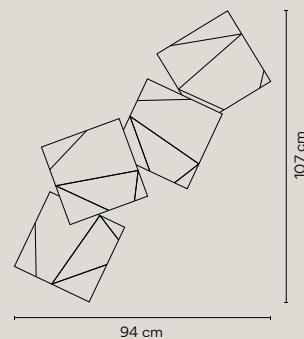



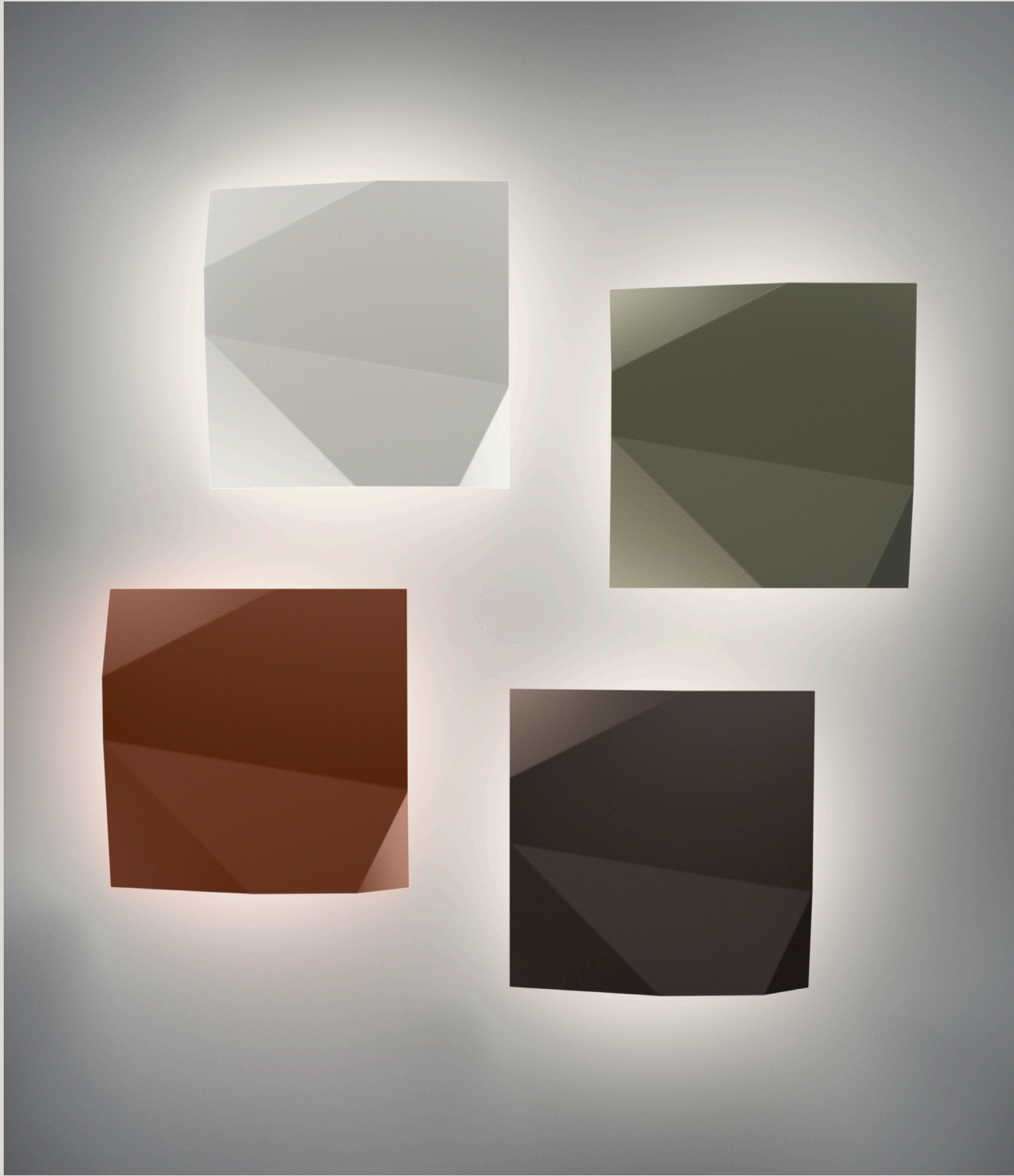

# Palo Alto

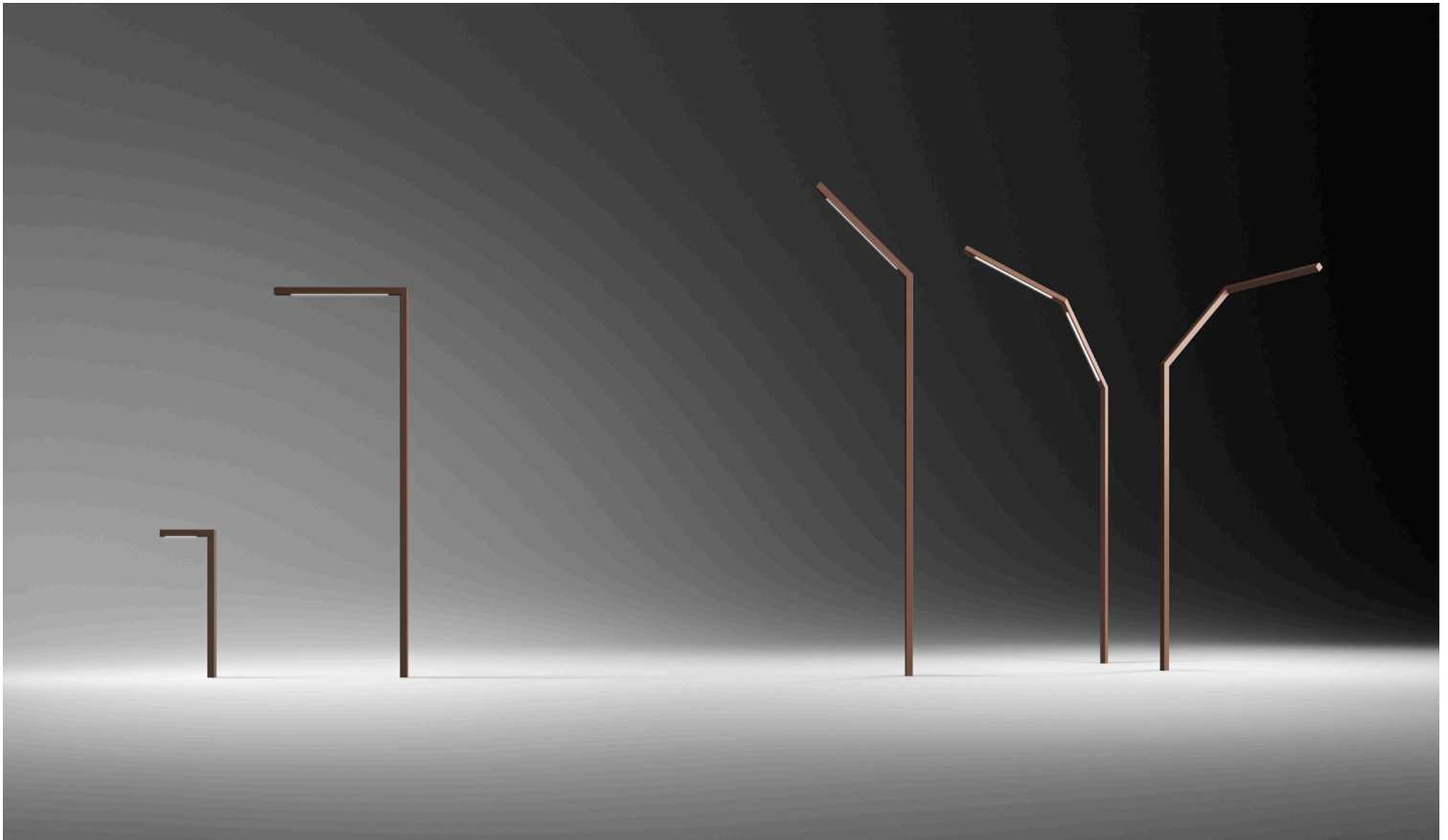

Design by Xuclà.

At once natural and architectural, Palo Alto creates the effect of illuminated landscaping. Its angular, tree-shaped silhouette integrates seamlessly with the outdoors whether displayed individually or in a group.













At once natural and architectural, Palo Alto creates the effect of illuminated landscaping. Sleek and streamlined, its angular, tree-shaped silhouette integrates seamlessly with the outdoors. It's offered in various minimalist shapes and can be displayed individually or in a group to resemble a stand of trees. The upper reaches of the sturdy steel fixture are fitted with slim swaths of LEDs directed downwards to create diffuse, ambient glow.

- 29 Brown D1 (NCS S 8005-Y50R)
- 53 Green M1 (NCS S 6005-G80Y)

Body: Steel.  
 Cover: Steel.  
 Diffuser: Polycarbonate.

LED 2700 K. CRI>80. 80 lm/W.

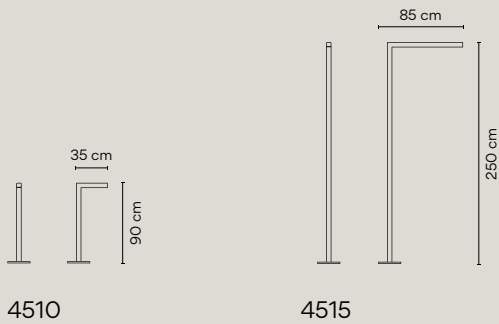

4510

4515

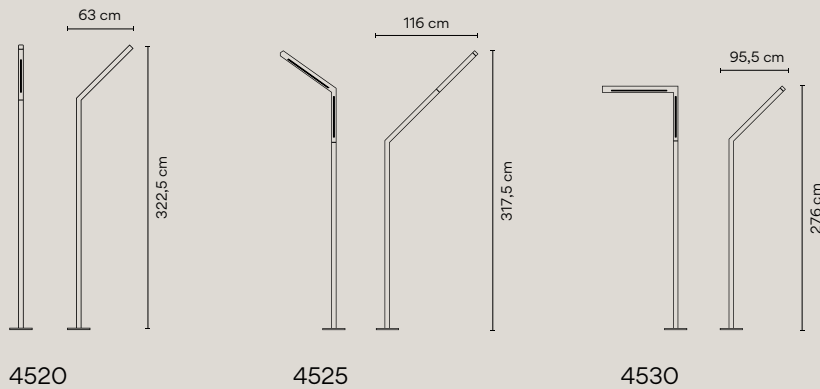

4520

4525

4530

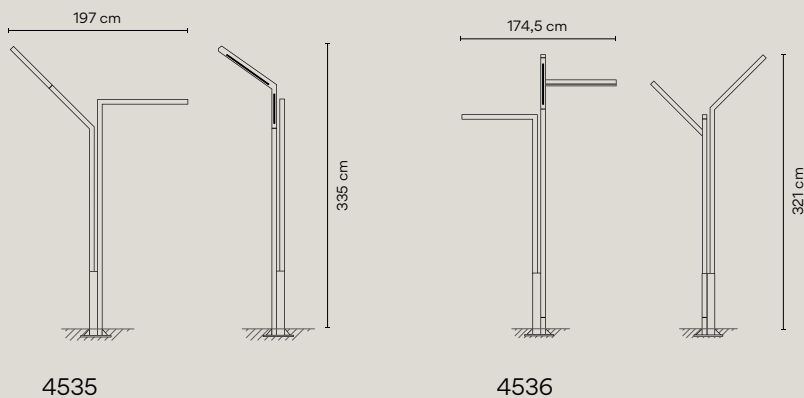

4535

4536

Ground surface mounted.

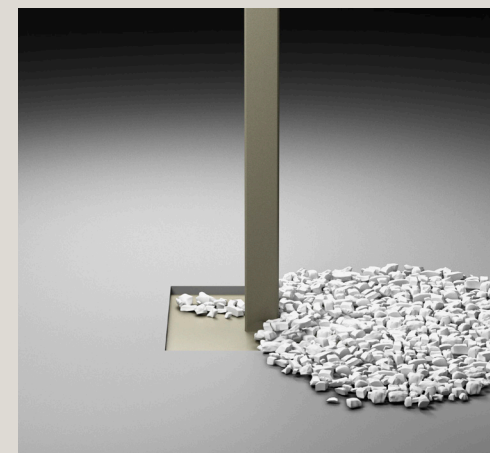
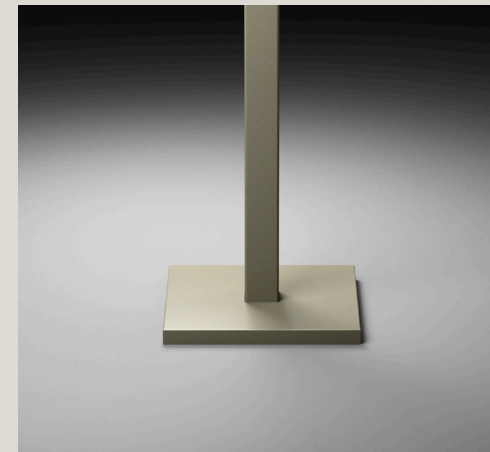



# Brisa

Design by Lievore, Altherr, Molina.

Inspired by the forest blue bell flower, Brisa adds a nature-inspired accent to any outdoor space. Its long, slender stem is topped with a hanging, conical shade and features adjustable, revolving arms.









Brisa adds a nature-inspired accent to any space. True to its name, which means breeze in Spanish, Brisa's silhouette is delicate and graceful. Its long, slender stem is topped with a hanging, conical shade that beautifully captures the bloom's languid look. The simple architecture and distinctive bowed head lend it a quiet presence that accents an outdoor space rather than overpowering it. Offered with 1, 3, or 5 arms, it resembles a solitary plant or grouping of flowers in a natural setting. The LED-powered light source casts a warm, bright beam, making it ideal for focused illumination. The collection is available in a surface mounted or built-in style.

- 07 Khaki (RAL 7039)
- 54 Oxide (RAL 8014)

Shade: Aluminum.  
 Base: Aluminum.  
 Disc: stainless steel.  
 Tube: Steel.

LED 2700K. CRI>80. 95 lm/W.

Ref. 4625.  
 Ground mounted spike version.

Ref. 4630, 4635, 4640.  
 Ground mounted recessed version.

#### Personalization options available

- LED 3000 K / 4000 K  
 Request more information.

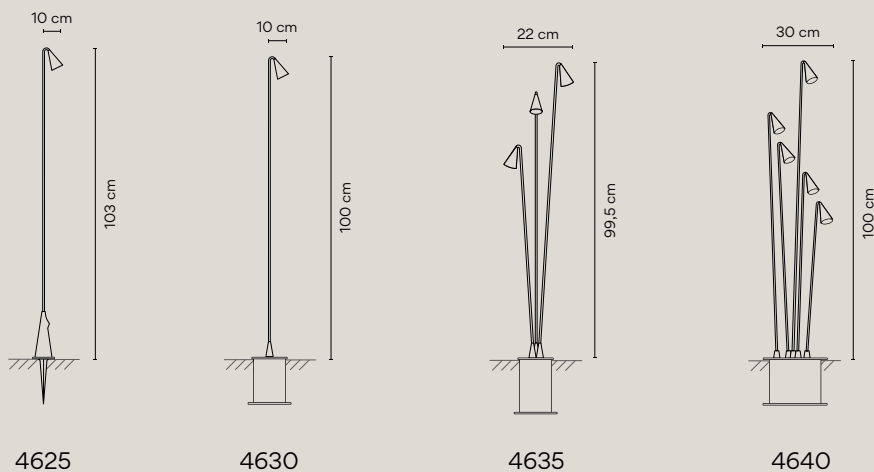
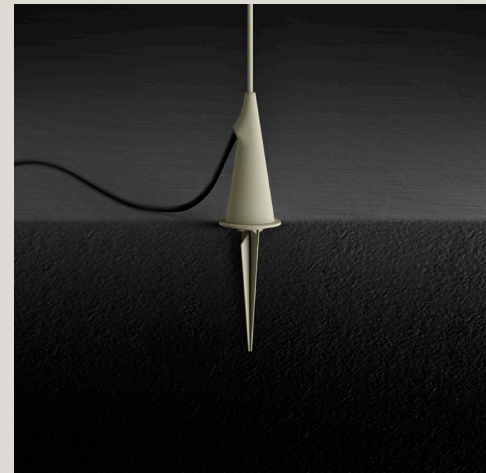
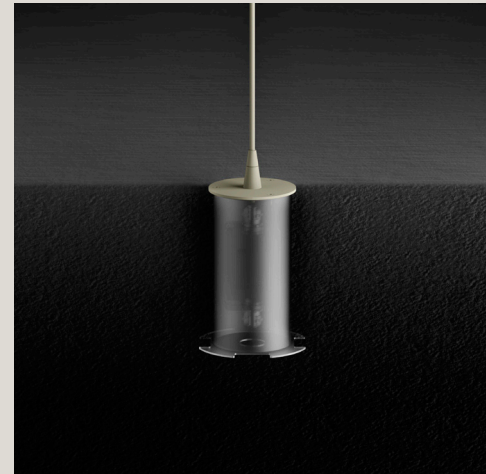







A photograph of a modern outdoor lighting fixture on a wooden deck at night. The fixture is a cantilevered perch with a glass top and a dark metal frame. It is illuminated from within, casting a warm glow. The background shows a cityscape at night with many lights, and a dark sky. The deck is made of dark wood planks. The overall mood is serene and modern.

# Empty

Design by Xuclà.

A sculpture by day and lighting by night, this outdoor fixture embodies multifunctional design. Its crisp angles create a cantilevered perch that serves as a side table or stool.







A sculpture by day and lighting by night, Empty is the embodiment of multifunctional design. Floor lamp and furnishing in one, Empty's crisp angles create a cantilevered perch that serves as a side table or stool, while making a sleek modernist statement. A LED light source tucked discreetly under the seat casts a warm glow that's ideal for walkways or general exterior illumination.

● 18 Concrete (S 2002-B50G)

Body: Polymer concrete.  
Diffuser: Methacrylate.

Ref. 4125, 4130.  
LED 3500 K. CRI>70. 73 lm/W.

Ref. 4135, 4136.  
LED 3500 K. CRI>70. 66 lm/W.

Ground surface mounted.

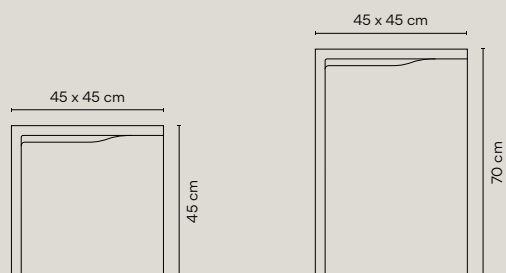
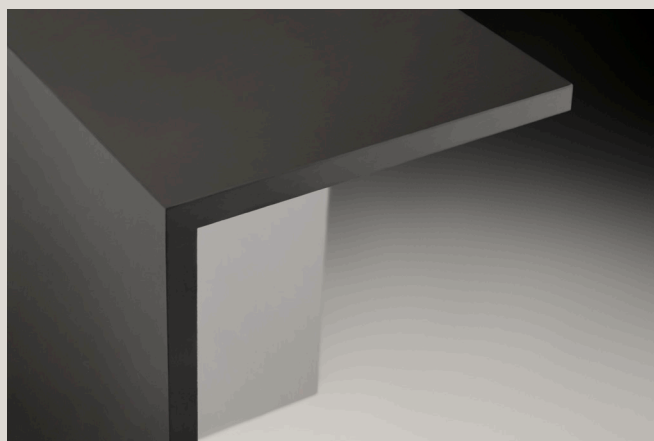
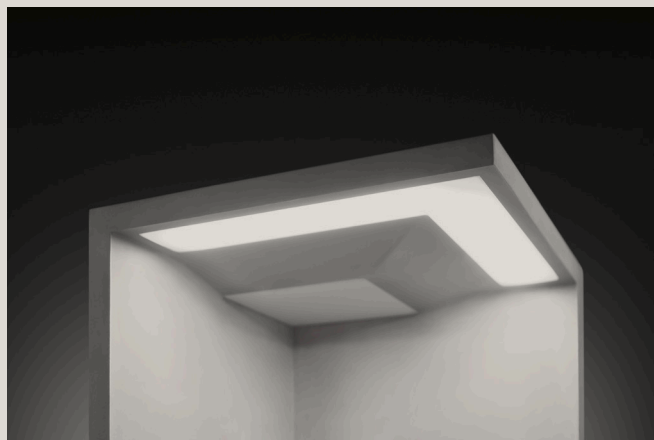

4125

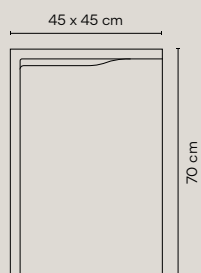

4130

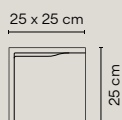

4135

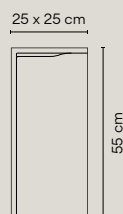

4136





# Bamboo





Design by Antoni Arola & Enric Rodríguez.

Bamboo's lean, natural form perfectly lends itself to an outdoor setting. Studded with LEDs, it seamlessly integrates with the landscape while adding a wash of light to walkways and common spaces.

Recalling the appearance of its namesake plant, Bamboo features a slender silhouette studded with LEDs along its lean frame. The natural form perfectly lends itself to an outdoor setting, seamlessly integrating with the landscape while adding a wash of light to walkways and common spaces. Bamboo is offered in one, two, or three pieces and is available in various heights.

- 07 Khakhi (RAL 7006)
- 54 Oxide (RAL 8017)
- 58 Off-White (Pantone Warm Gray 2U)

Body: Resin / glass fiber.  
Diffuser: Methacrylate.

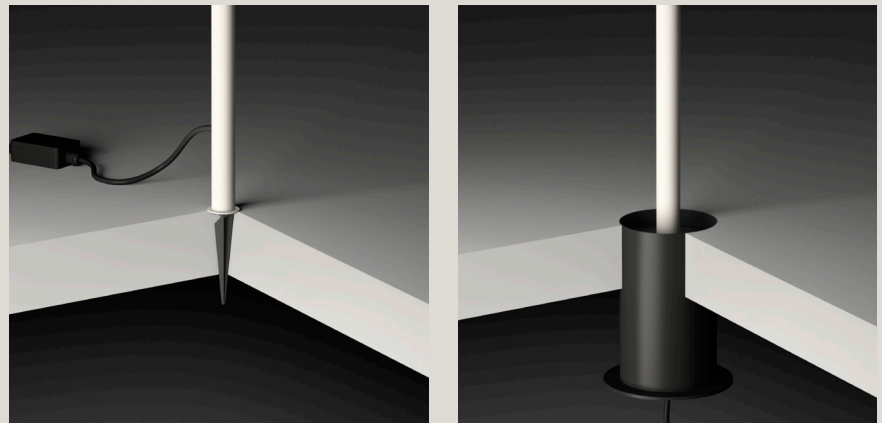

LED 2700 K. CRI>80. 95 lm/W.

Ref. 4800, 4801.  
Ground mounted spike version.

Ref. 4802, 4803, 4804, 4805, 4810, 4811, 4812.  
Ground mounted recessed version.

Ref. 4815.  
Accessory.

Ref. 4820.  
Wall mounted version.

**Personalization options available**  
- LED 3000 K / 4000 K  
Request more information.

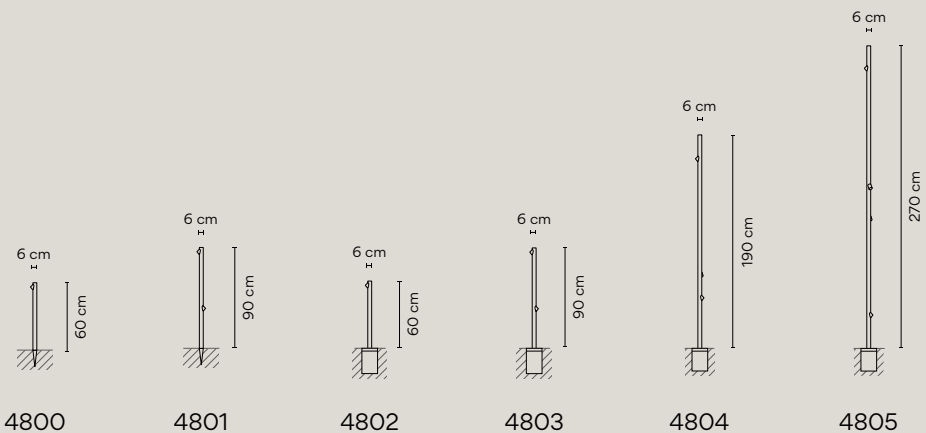

4800      4801      4802      4803      4804      4805

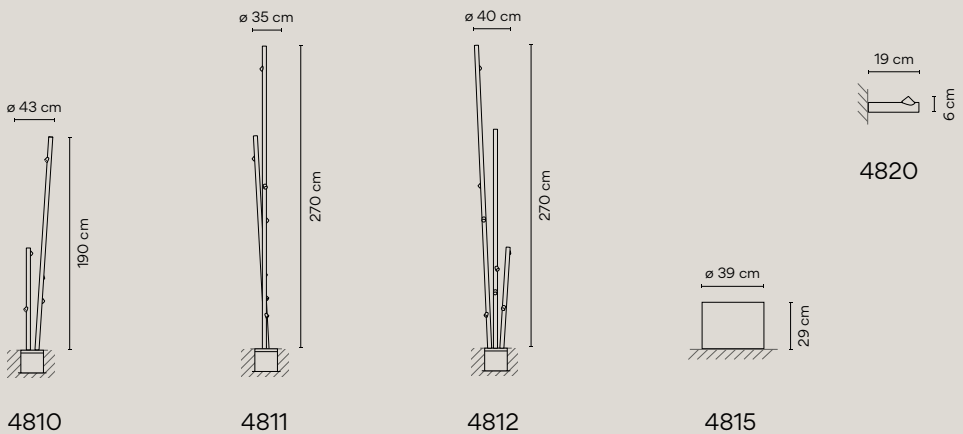

4810      4811      4812      4815      4820



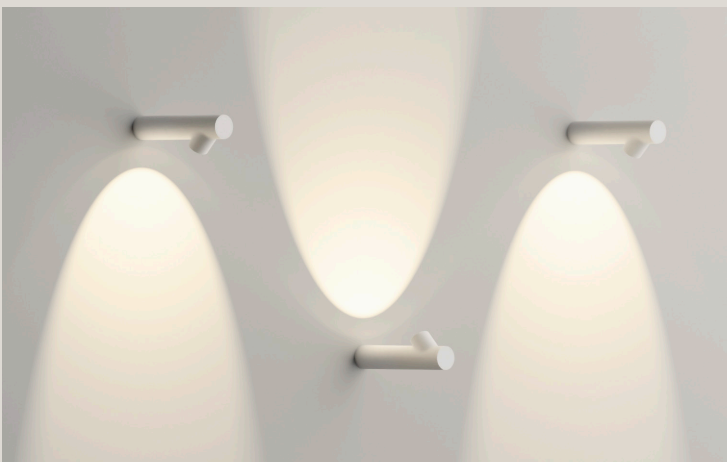



# Wind

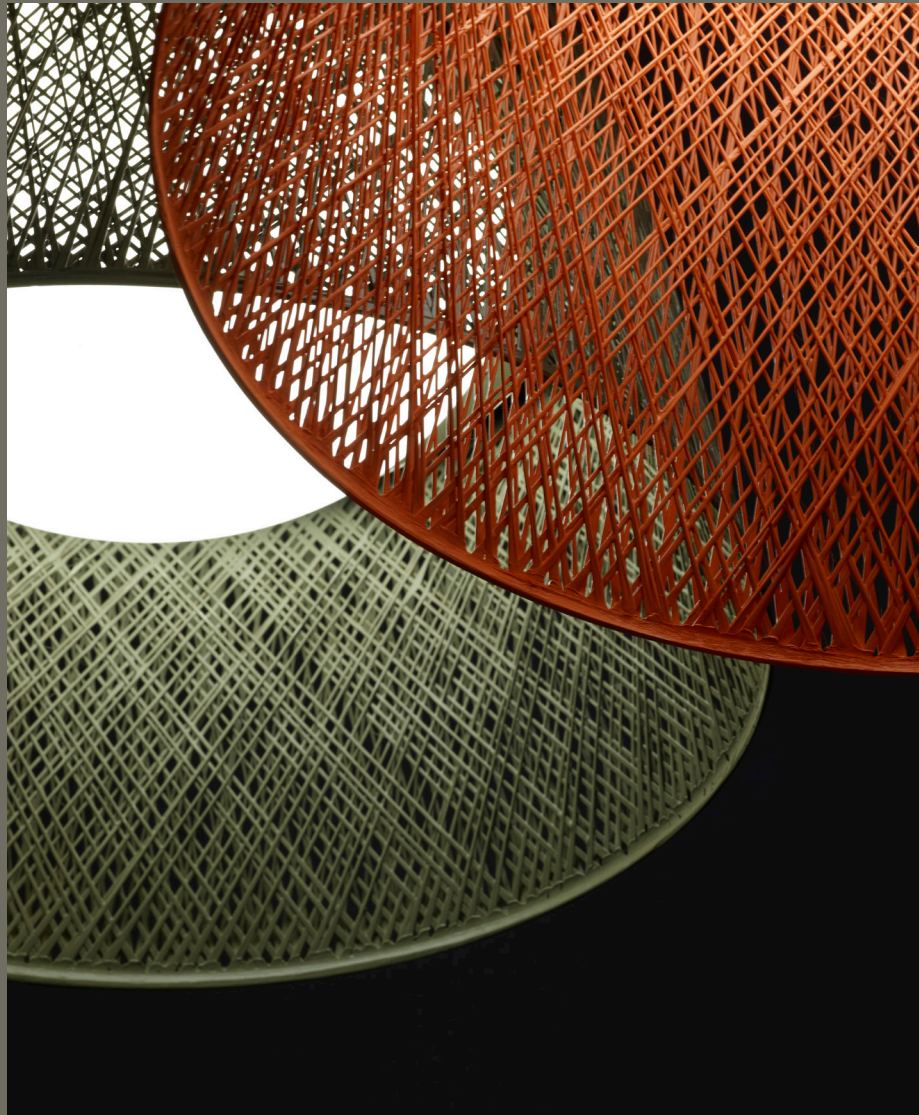

Design by Jordi Vilardell.

A perfect marriage of technology and tradition. Wind's drum shade is made of fibreglass, an innovative webbed texture and pattern that elevates the visual contribution of this timeless silhouette.











Distinguished by its large scale and striking silhouette, Wind makes a to-wering statement in any outdoor setting. A perfect marriage of technology and tradition, the drum shade is intricately woven of fibreglass, creating a webbed texture and pattern that elevates its textural interest and makes it versatile enough for traditional or modern settings. Wind is available in a pendant and floor versions and emits an ambient glow.

- 27 Brown L1 (S 1505-Y50R)
- 53 Green M1 (S 6005-G80Y)
- 61 Ocre red (S 3050-Y60R)

Shade: Filament winding.  
 Cover: Steel.  
 Weight: Concrete.  
 Diffuser: Methacrylate.  
 Lid: Steel.

LED 2700K. CRI>90. 139 lm/W.

Ref. 4057, 4062, 4067.  
 Portable version.

Ref. 4072, 4077.  
 Surface mounted.

#### Personalization options available

Ref. 4072, 4077.  
 - Extra cable length.  
 Request more information.

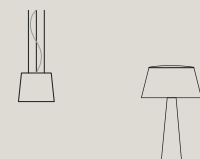
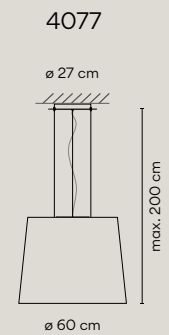
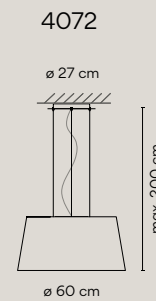
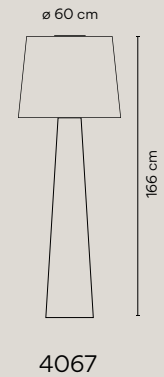
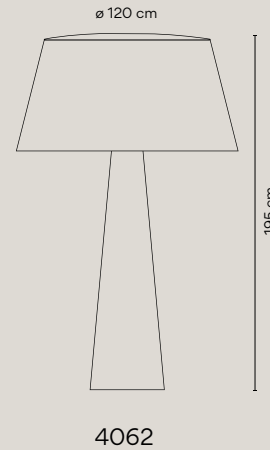





# Break

Design by Xuclà & Alemany.

Resembling an avant-garde sculpture, Break is distinguished by its architectural attitude. The cubic volumes angle provides down light, while doubling as sculptural outdoor presence.

















Resembling an avant-garde sculpture, Break is distinguished by its architectural attitude. The fixture features cubic volumes angle provides down light, while doubling as sculptural presence to complement an outdoor setting. Break is available in two types of floor lamps-one a beveled cube that creates a powerful beam of light to illuminate the area around it; the other a vertical stack of two shapes through which light shines. It's also offered in a wall lamp, which reflects light outwards through a slot between it and the wall on which it's mounted.

- 07 Khakhi (Ral 7006)
- 54 Oxide (Ral 8017)
- 80 Concrete (Natural finish)

Ref. 4101, 4106.

Body: Polyurethane / concrete.

Base: Polyurethane / concrete.

Diffuser: Methacrylate.

Ref. 4108.

Body: Steel.

Base: Steel.

Diffuser: Methacrylate.

Ref. 4110.

Body: Aluminum / concrete.

Diffuser: Methacrylate.



Ref. 4101, 4106.

LED 2700 K. CRI>80. 94 lm/W.

Ref. 4108.

LED 2700 K. CRI>80. 118 lm/W.

Ref. 4110.

LED 2700 K. CRI>80. 95 lm/W.

Ref. 4101, 4106, 4108.

Ground mounted.

Ref. 4110.

Wall mounted.

#### Personalization options available

- LED 3000 K / 4000 K

Request more information.

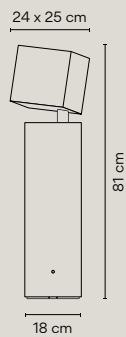

4101

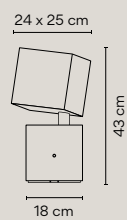

4106

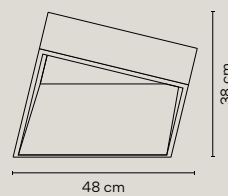

4108

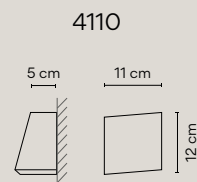

4110



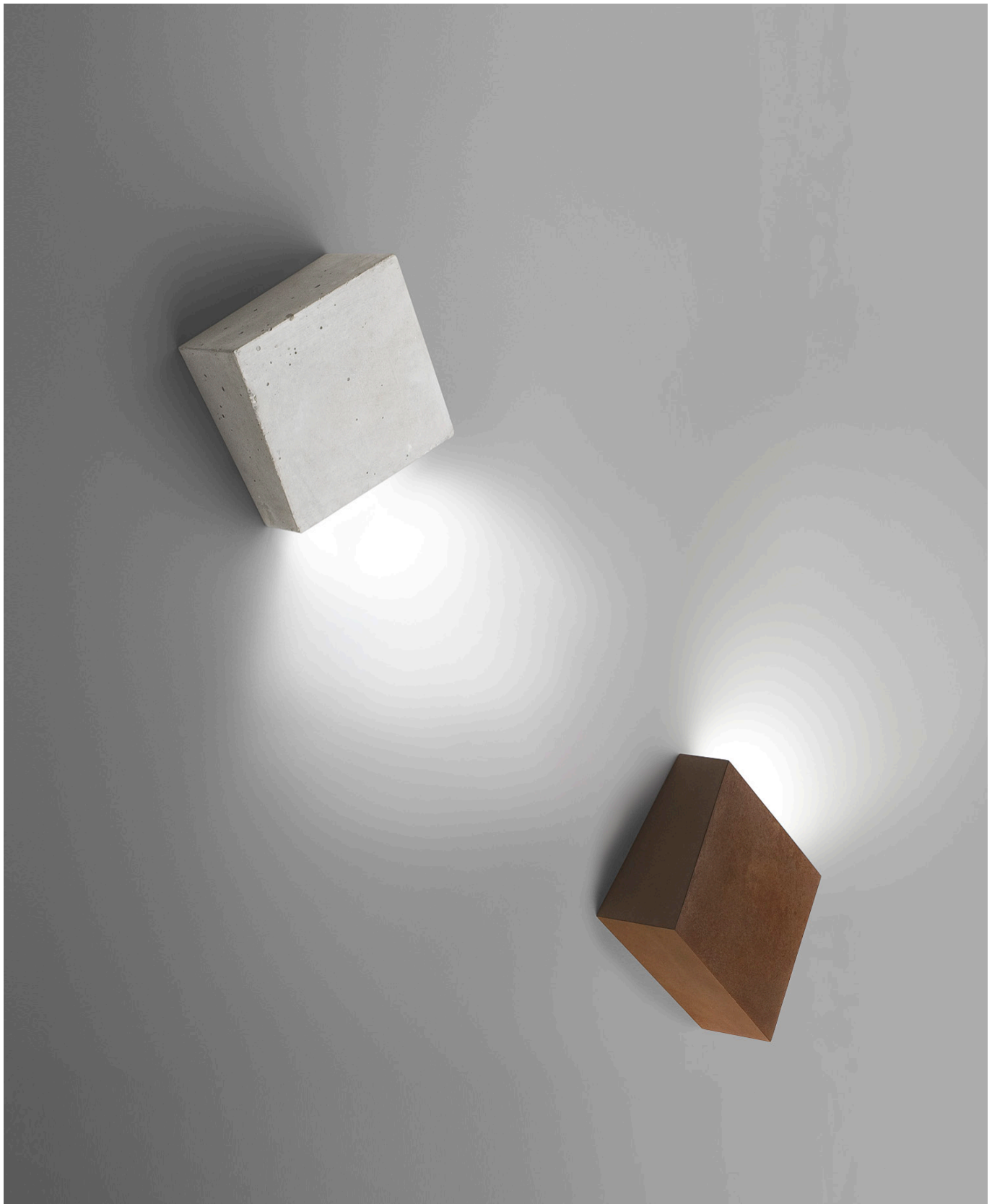



# Plus

Design by X. Claramunt & M. de Mas.

Adopting the form and function of a skylight, Plus' streamlined, spherical form integrates seamlessly into the ceiling architecture of outdoor spaces like porches or walkways. Its diffuser lends the dimmable light an ambient, uniform quality.

---

● 03 White (RAL 9010)

Body: Polyurethane.  
Diffuser: Methacrylate.  
Ceiling support: Steel.

---

Ref. 0630.  
Fluorescent tube.  
Dimming: DALI, Push.

Ref. 0632.  
LED 3000 K. CRI>90. 112 lm/W.  
LED 4000 K. CRI>80. 131 lm/W.  
Dimming: DALI, 1-10V, Push.

Surface mounted.

---

## Personalization options available

Ref. 0632.  
- Dimming: Casambi  
Request more information.

0630 0632

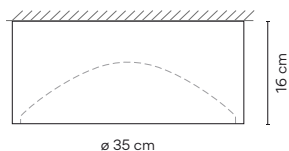



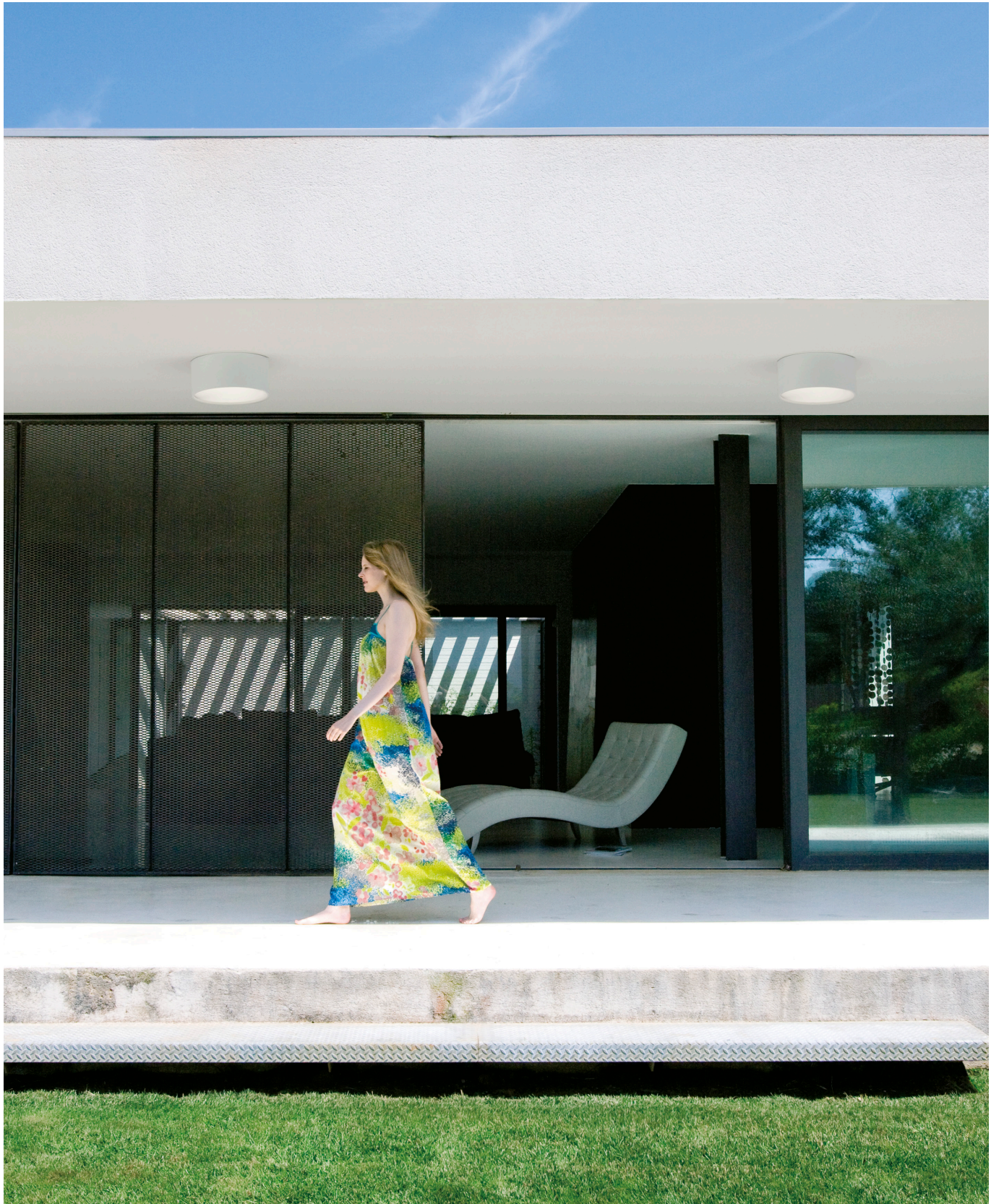







# June



Design by Ana Mir + Emili Padrós (emiliana design studio).

Inspired by traditional lanterns, June recall garlands festooned throughout an outdoor space. Its moon-like spheres cast a warm, ambient glow.











Inspired by traditional lanterns, June translates the iconic image of illuminated globes into a refined collection. Its moon-like spheres recall garlands festooned throughout a courtyard, garden, or patio, casting a warm, ambient glow. The LED-powered fixture offers focused, yet diffuse illumination, bathing a surface in soft, indirect light from above. The luminous spheres are available as a pendant (portable, single-support, or a double-support versions), floor lamp, or table lamp.

● 54 Brown (Pantone Black U)

Shade: Polycarbonate.  
Diffuser: Opal blown glass.  
Tube: Steel.

Ref. 4790, 4795.  
Body: Aluminum.

LED 2700 K. CRI>80. 121,7 lm/W.

Ref. 4770, 4775.  
Ground mounted spike version.

Ref. 4780, 4785.  
Ground mounted recessed version.

Ref. 4790.  
Portable version with battery.  
Charge by removable cable.  
Battery life from 6 to 18 hours  
(depending on intensity).

Ref. 4795  
Portable version with battery.  
Tray with 3 units. Charge by contact.  
Battery life from 6 to 18 hours  
(depending on intensity).

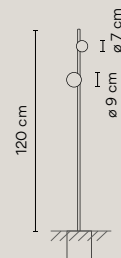
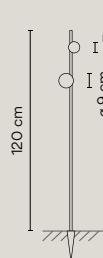
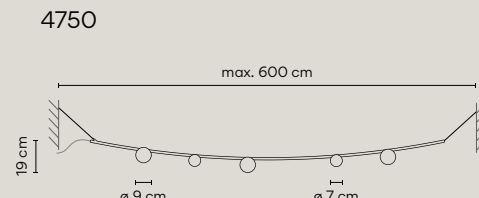
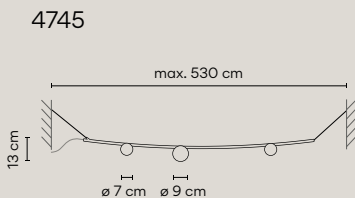
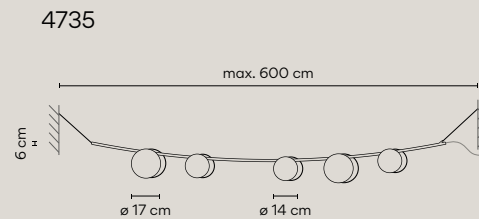
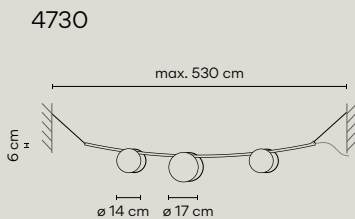

4770

4775

4780

4785

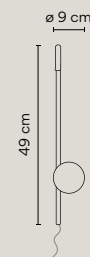

4765



4790

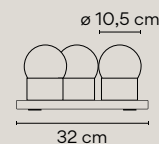

4795

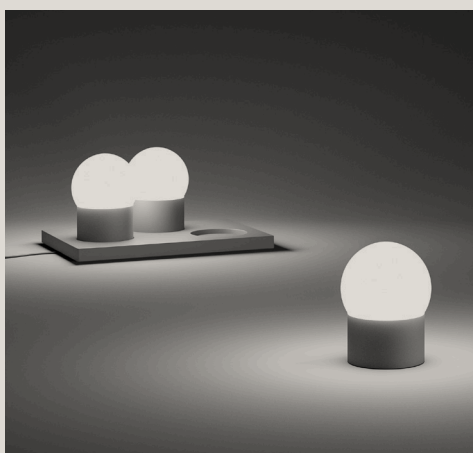









# Micro

Design by Ramos & Bassols.

Powered by an LED light source tucked between its two circular forms, Micro's diminutive design recalls a solar eclipse casting a glowing nimbus of light.



As its name suggests, Micro is distinguished by a diminutive, yet precise design that measures a mere 10 centimeters.

A pleasing interplay of concentric circles, its simple, spherical base attaches to the wall and is superimposed by a smaller, protruding ring. Powered by an LED tucked between the two layers, it recalls a solar eclipse casting a glowing nimbus of light.

● 03 White (Ral 9016)

● 54 Oxide (Ral 8017)

Body: Aluminum.

Diffuser: Polycarbonate.

LED 2700 K. CRI>80. 122 lm/W.

Surface mounted.

**Personalization options available**

- LED 3000 K / 4000 K

Request more information.



2015

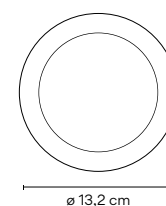
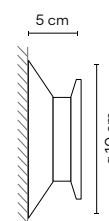



# Scotch

Design by Oscar & Sergi Devesa.

Evoking a sleek ice sculpture,  
Scotch is at once strong and subtle.





Crafted of a thick, pressed-glass diffuser resting upon a chrome base, its simple, spherical design provides an understated accent. It features a frosted-glass interior that generates a warm glow, ideal for outdoor ceiling soffits or walls.

● 01 Chrome

Body: Zamak.  
Diffuser: Glass.

LED 2700 K. CRI>80. 117,3 lm/W.

Surface mounted.

**Personalization options available**

- LED 3000 K / 4000 K  
Request more information.

0962

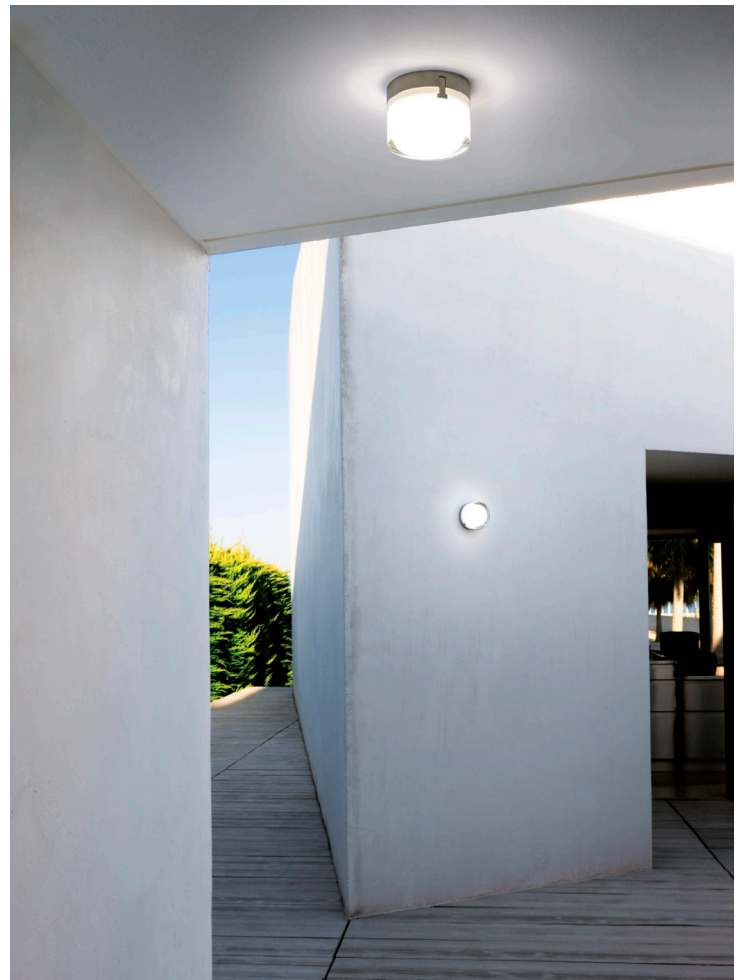
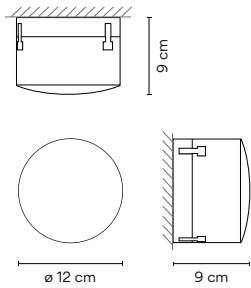



# Plis Outdoor

Design by Ramos & Bassols.

A surprising design which brings the warm atmosphere and textures of the indoors to the garden, terrace or porch. Breaking down boundaries between inside and outside.

---

Marked by its tailored pleated shade, Plis features the classic silhouette of an indoor lamp reimagined for the outdoors. Free of any embellishment apart from the crisp pleating, Plis provides a contemporary, yet timeless feel. Available in a floor version, it casts a warm, welcoming glow.

● 03 White (RAL 9016)

Base: Polyurethane.  
Cover: Steel.  
Diffuser: Polyethylene.

---

Compact fluorescent.

---

Ref. 4030.  
Portable version with cable.

Ref. 4035.  
Ground surface mounted.

---

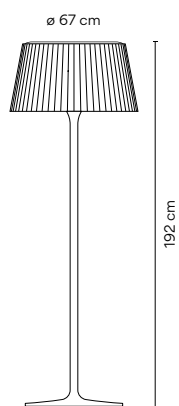

4030 4035







# Meridiano

Design by Jordi Vilardell & Meritxell Vidal.

Meridiano features a grid of steel slots through which LED light radiates outwards in a dramatic sunburst pattern. Topped with foam, it doubles as a seat or side table, its airy architecture integrating easily into outdoor spaces.











Meridiano is formed from a spherical steel shade fitted with open slots. An ambient LED shines through the glass diffuser, radiating outward from the grid across a broad surface in a dramatic sunburst pattern of shadow and light. Topped with foam, it doubles as a seat or side table, its airy architecture integrating easily into outdoor spaces.

- 07 Khakhi (RAL 7006)
- 58 Off-white (PANTONE WARM GRAY 2U)
- 62 Green (RAL 6021)

Rods: Steel.  
 Arm: Steel.  
 Seat: Polyurethane.  
 Diffuser: Glass.

LED 2700 K. CRI>80. 116 lm/W.

Ref. 4710, 4715.  
 Ground surface mounted.

Ref. 4720.  
 Wall surface mounted.

4720

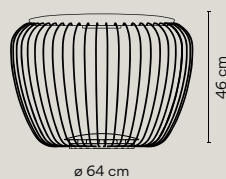
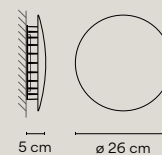

4710

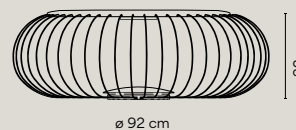

4715











