



WITH  
LODES

2023 Lighting assortment



WITH  
LODES

# Contents

12 **Magic Mushroom**

22 **Reglobe**

32 **U.F.O.**

42 **ROD**

52 **Spring**

64 **Cage**

72 **Flask**

82 **Fork**

92 **Gask**

98 **Glass Drop**

106 **Pipe**

112 **Urban Concrete**

124 **Vinyl**

# Magic Mushroom



# Magic Mushroom

L'effetto trasparente del diffusore è realizzato con un vetro effetto color acqua che, attraverso il suo aspetto liquido, crea l'illusione del riflesso dell'acqua sulla parete grazie alla proiezione della luce filtrata dal vetro.

The Aqua-coloured glass is transparent and has a fluid, liquid character. The shade filters and projects light in a similar way to the reflection of water on a surface or wall thanks to the projection of the light filtered by the glass.





# Magic Mushroom









# Magic Mushroom New

Table

## Magic Mushroom New



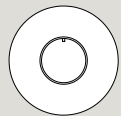

ø 14.96"  
ø 38 cm

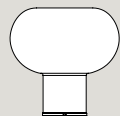

14.96"  
38 cm

ø 6.06"  
ø 15.4 cm



Light source Sorgente luminosa	Structure Montatura	Diffuser Diffusore	Code Codice	N. America Code
LED E27 T30 Tubular L / W 225 mm 1 × 25 W	 Black	 Aqua	<b>52280 0000</b>	—
LED Medium Base T30 Tubular L / W 225 mm 1 × 25 W	 Black	 Aqua	—	<b>52280 0000U</b>
Bulb not included Dimmer on the cord included				
Lampadina non inclusa Dimmer nel filo incluso				

Net Weight / Peso Netto: 7.5 kg

Pack / Colli: 2



Light source Sorgente luminosa	Dimension Dimensione	Pack Colli	Code* Codice
E27 T30 2500 K 6 W / 620 lm	L / W 225 mm L / W 8.85"	1	<b>191A02</b>

\* Not available for N.America



# Reglobe

Reglobe brings the 1960s into the 21st century thanks to a special industrial process that uses rotational moulding to assemble recycled plastic grains of different colours, reproducing a terrazzo effect. A large, yet lightweight pendant, Reglobe features a white terrazzo finish with vibrant colour accents.

Reglobe porta gli anni '60 nel ventunesimo secolo grazie ad un particolare processo industriale che sfrutta il rotational moulding per assemblare grani di plastica riciclata di diversi colori, riproducendo un effetto terrazzo. Reglobe è una sospensione di grande dimensione ma leggera, caratterizzato da una finitura terrazzo bianca con vivaci accenti di colore.

# Reglobe







# Reglobe

The lamp's opaque sphere houses a white conical metal diffuser at the bottom, which prevents light from filtering through. The light source contains the connection for an E27 bulb that diffuses light downwards. Each individual Reglobe unit is unique, with colour tones varying depending on the blending method used during the production process. Available in three sizes (Ø45, Ø55, Ø65 cm) and in a Random Terrazzo finish that varies according to the combination of recycled polyethylene, Reglobe has a dimmer that can be adjusted from the switch.

Reglobe,  
Random Terrazzo



La lampada è caratterizzata da una sfera opaca che ospita nella parte inferiore un diffusore di metallo dalla forma conica di colore bianco, che rende opaco l'oggetto stesso impedendo alla luce di filtrare. La fonte luminosa racchiude al suo interno l'attacco per una lampadina E27 che diffonde la luce verso il basso. Ogni singola unità di Reglobe è un pezzo unico: le tonalità cromatiche variano infatti a seconda delle modalità di miscela nel corso del processo produttivo. Disponibile in tre dimensioni (Ø45, Ø55, Ø65 cm) e in finitura Random Terrazzo – che varia di volta in volta a seconda della combinazione del polietilene riciclato – Reglobe dispone di dimmer regolabile dall'interruttore.

Reglobe,  
Recycled polyethylene



# Reglobe







# Reglobe New

Suspension lamp

## Reglobe 45 New

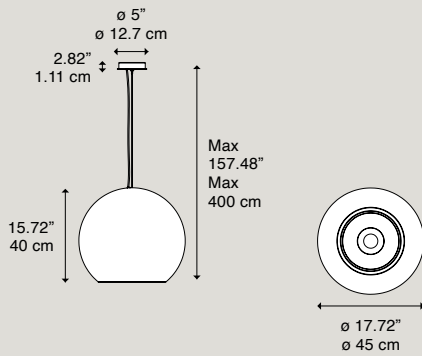

Net Weight / Peso Netto: 3.1 kg

Pack / Colli: 1

Light source Sorgente luminosa	Inside diffuser Diffusore interno	Outside diffuser Diffusore esterno	Code Codice	N. America Code
LED E27 1 max 25W	White	Random Terrazzo	52321 1100	—
LED Medium Base 1 max 25W	White	Random Terrazzo	—	52321 1100U
BULBS not included LAMPADINE non include				

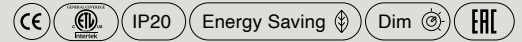

Suspension lamp

## Reglobe 55 New

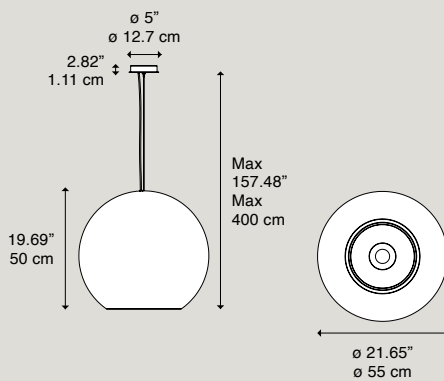

Net Weight / Peso Netto: 4.1 kg

Pack / Colli: 1

Light source Sorgente luminosa	Inside diffuser Diffusore interno	Outside diffuser Diffusore esterno	Code Codice	N. America Code
LED E27 1 max 25W	White	Random Terrazzo	52322 1100	—
LED Medium Base 1 max 25W	White	Random Terrazzo	—	52322 1100U
BULBS not included LAMPADINE non include				

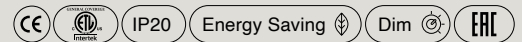

Suspension lamp

## Reglobe 65 New

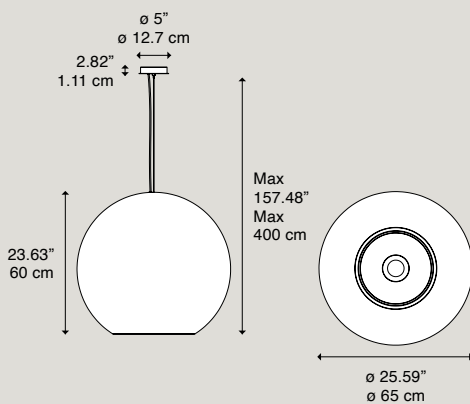

Net Weight / Peso Netto: 5.8 kg

Pack / Colli: 1

Light source Sorgente luminosa	Inside diffuser Diffusore interno	Outside diffuser Diffusore esterno	Code Codice	N. America Code
LED E27 1 max 25W	White	Random Terrazzo	52323 1100	—
LED Medium Base 1 max 25W	White	Random Terrazzo	—	52323 1100U

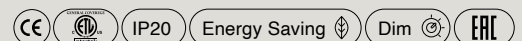

# U.F.O.

U.F.O., a pendant lamp whose name recalls the imagery of Unidentified Flying Objects, features a minimalist design reminiscent of the late 1990s.

U.F.O. consists of a wide and flattened metal diffuser, designed to have a minimal visual presence that does not obstruct the surrounding space. Its punctual and homogeneous light is emitted downwards from the LED, making it the perfect pendant lamp for illuminating a table. U.F.O. is available in two sizes (Ø35 and Ø60 cm) and three finishes: Black, Rust, and Sand. In terms of light source, it is available in 2700K and 3000K versions.

U.F.O. è una lampada a sospensione il cui nome richiama all'immaginario degli Unidentified Flying Object, le cui forme richiamano al minimalismo caratterizzante degli ultimi anni '90. U.F.O. si compone di un diffusore di metallo largo e schiacciato: la sua sottile leggerezza mira a non occludere lo spazio, rendendo protagonista la sua luce – puntuale ed omogenea – diffusa verso il basso dal LED. Questa caratteristica rende U.F.O. la sospensione perfetta per illuminare un tavolo. U.F.O. è disponibile in due dimensioni (Ø35, Ø60 cm) e in tre finiture: Black, Rust e Sand. Per quanto riguarda la fonte luminosa, è disponibile nelle versioni 2700 K e 3000K.

U.F.O.,  
Ø 35 and Ø 60 cm



**U.F.O.**



U.F.O., Ø 60 cm







U.F.O., Sand and Black



U.F.O., Rust

## U.F.O.

The lower part of the lamp, thanks to its semi-conical shape, sits harmoniously with the conical shaped diffuser. While it can illuminate a large portion of the space below, it also emits a gentle glow upwards, giving the lamp an overall light appearance, making it seem almost suspended in the air.

La sorgente luminosa, grazie alla sua forma semiconica, dialoga coerentemente con il diffusore dalla forma conica. Oltre ad illuminare verso il basso un'ampia porzione di spazio, emette anche un leggero bagliore e verso l'alto, creando così un effetto che alleggerisce la percezione dell'oggetto stesso e facendolo sembrare quasi sospeso nell'aria.



**U.F.O.**



U.F.O., Ø 60 cm





# U.F.O New

Suspension lamp

## U.F.O. 35 New

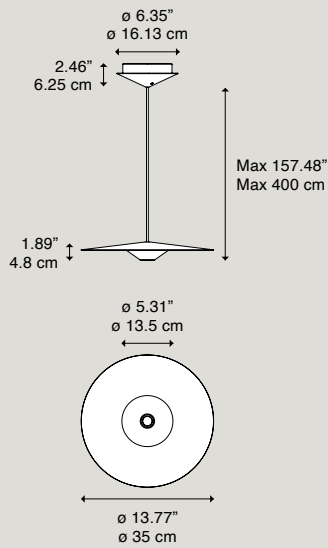

Light source Sorgente luminosa	Inside diffuser Diffusore interno	Outside diffuser Diffusore esterno	Code Codice	N. America Code
LED, 2700K 25.6 W / 3261 lm 700 mA CRI 90 MacAdam 2-Step	Black	Black	52121 2027	—
	Black	Sand	52121 9327	—
	Black	Rust	52121 9427	—
LED, 3000K 25.6 W / 3474 lm 700 mA CRI 90 MacAdam 2-Step	Black	Black	52121 2030	—
	Black	Sand	52121 9330	—
	Black	Rust	52121 9430	—
LED, 2700K 25.6 W / 3261 lm 700 mA CRI 90 MacAdam 2-Step	Black	Black	—	52121 2027U
	Black	Sand	—	52121 9327U
	Black	Rust	—	52121 9427U

LED and DRIVER included  
LED e DRIVER inclusi

Net Weight / Peso Netto: 1.6 kg

Pack / Colli: 2

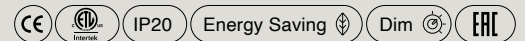

Suspension lamp

## U.F.O. 60 New

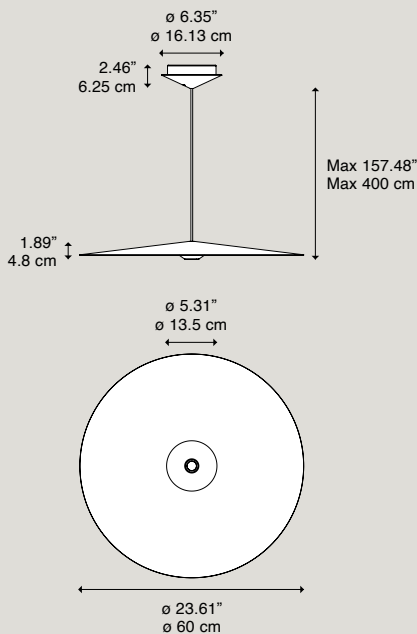

Light source Sorgente luminosa	Inside diffuser Diffusore interno	Outside diffuser Diffusore esterno	Code Codice	N. America Code
LED, 2700K 25.6 W / 3261 lm 700 mA CRI 90 MacAdam 2-Step	Black	Black	52121 2027	—
	Black	Sand	52121 9327	—
	Black	Rust	52121 9427	—
LED, 3000K 25.6 W / 3474 lm 700 mA CRI 90 MacAdam 2-Step	Black	Black	52121 2030	—
	Black	Sand	52121 9330	—
	Black	Rust	52121 9430	—
LED, 2700K 25.6 W / 3261 lm 700 mA CRI 90 MacAdam 2-Step	Black	Black	—	52122 2027U
	Black	Sand	—	52122 9327U
	Black	Rust	—	52122 9427U

LED and DRIVER included  
LED e DRIVER inclusi

Net Weight / Peso Netto: 2.5 kg

Pack / Colli: 2

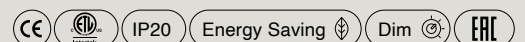



# ROD



ROD, View of the base

ROD's design concept originates from the form of a construction ROD. The slender stem connects two imaginary blocks of cement, rising from the base and supporting the shade, which hosts the LED light source. To adjust the level of light, the user can simply touch the top of the shade.

Il concetto di design di ROD ha origine dalla forma di un'asta da costruzione. Lo stelo sottile collega due blocchi immaginari di cemento, che salgono dalla base e sostengono il paralume, che ospita la sorgente luminosa a LED. Per regolare il livello di luce, l'utente può semplicemente toccare la parte superiore del paralume.

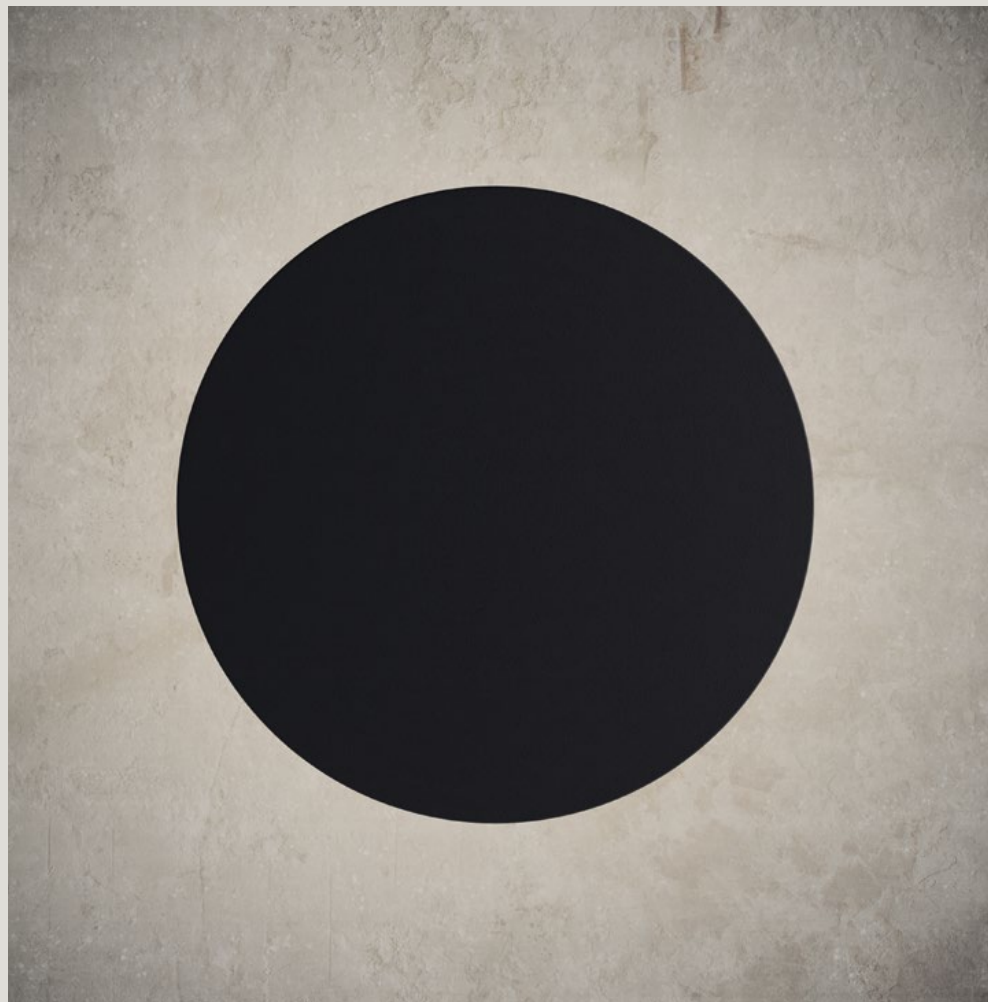

ROD, Dark Asphalt



# Rod





# ROD

Small yet robust, the lamp is portable and rechargeable via a C-type-USB port, which is protected by a rubber cap. This specific feature allows the light to be protected from dust, dirt and splashes, making ROD a perfect choice for use within hospitality venues as well as residential settings. Available in Moss Gray, Soft Pink, Ivory and Dark Asphalt, this new table lamp has a color to suit every mood.

Di piccole dimensioni ma robusta, la lampada è portatile e ricaricabile tramite una porta USB di tipo C, protetta da un tappo di gomma. Questa caratteristica specifica permette alla luce di essere protetta da polvere, sporcizia e schizzi, rendendo ROD una scelta perfetta per l'uso all'interno di luoghi hospitality così come in contesti residenziali. Disponibile in Moss Gray, Soft Pink, Ivory e Dark Asphalt, questa nuova lampada da tavolo ha una finitura che si adatta ad ogni mood.



ROD, Soft Pink

ROD, Dark Asphalt



# Rod





# ROD

Table

## ROD Cordless table lamp

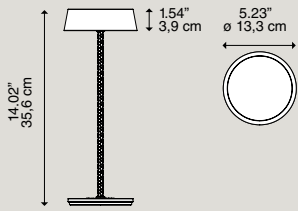

Colors	Code / Codice
Dark Asphalt	51181 2030
Soft Pink	51181 9130
Ivory	51181 5630
Moss Gray	51181 9230

Net Weight/ Peso Netto: 0.87 kg

Pack/ Colli: 1



Charging chart codice/code: 51500 2000/51500 2000U



The lamp is rechargeable via C-type-USB port

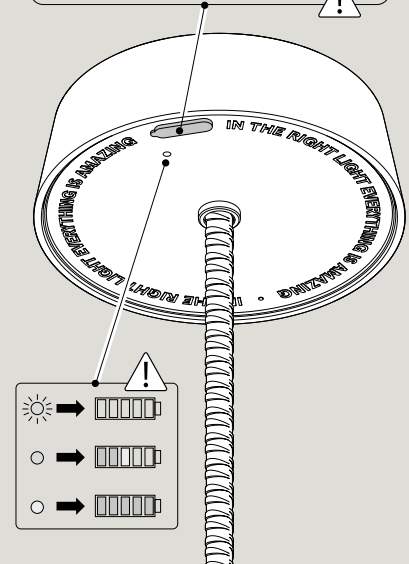
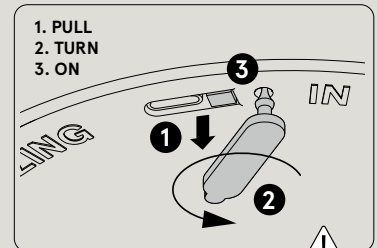
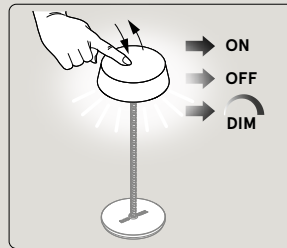

Moss Gray



Soft Pink



Dark Asphalt



Ivory

ROD, Ivory, Dark Asphalt

**Materials** aluminum base, steel stem, aluminum head and methacrylate diffuser

**Light** LED, 2 W, 3000K, CRI 95, 212 lm, MacAdam 3-Step

**Colors** Moss Gray, Soft Pink, Ivory, Dark Asphalt

**Battery (included)** Charging time: power supply 1,4A= 3 h  
Life: full power (100%) = 8h, half power (50%) = 48h, minimum power (10%) = 180 h

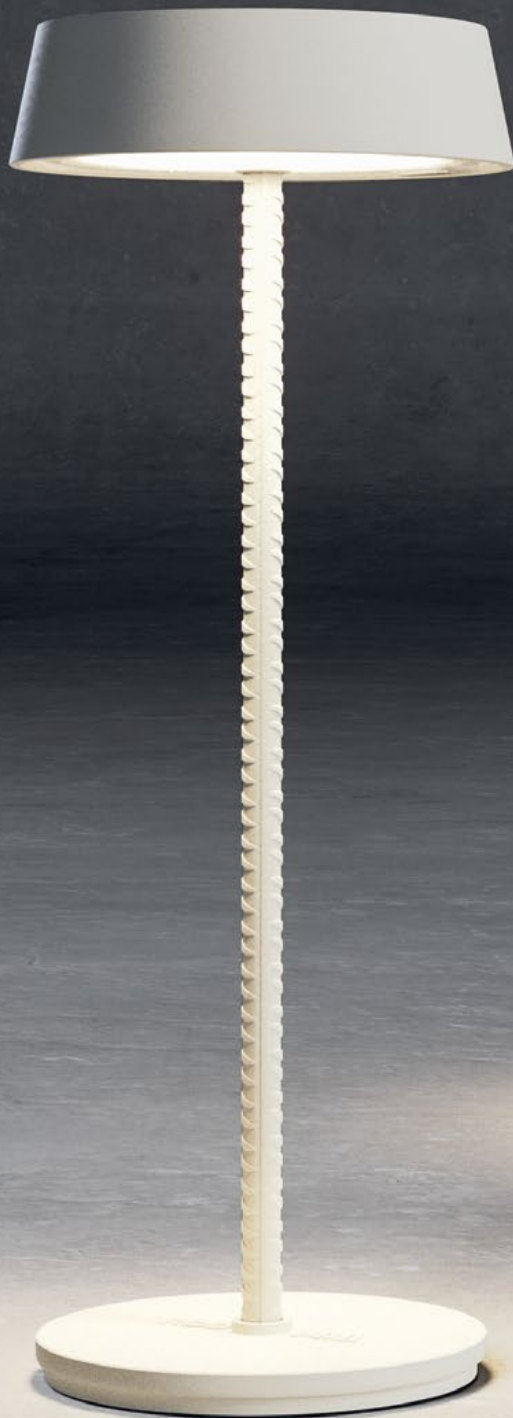



**Spring has been extended to include a floor lamp version, following the arm and ceiling models.**

**Inspired by a safety pin that gives the lamp a distinctive look thanks to its minimal and elegant graphic sign, Spring recalls the world of fashion.**

La collezione Spring si amplia con una versione da terra che segue il design delle versioni a parete e soffitto, la cui lavorazione richiama il principio della spilla da balia grazie ad un segno grafico minimale ed elegante che richiama il mondo fashion.

# Spring



Spring ceiling, Deep Black



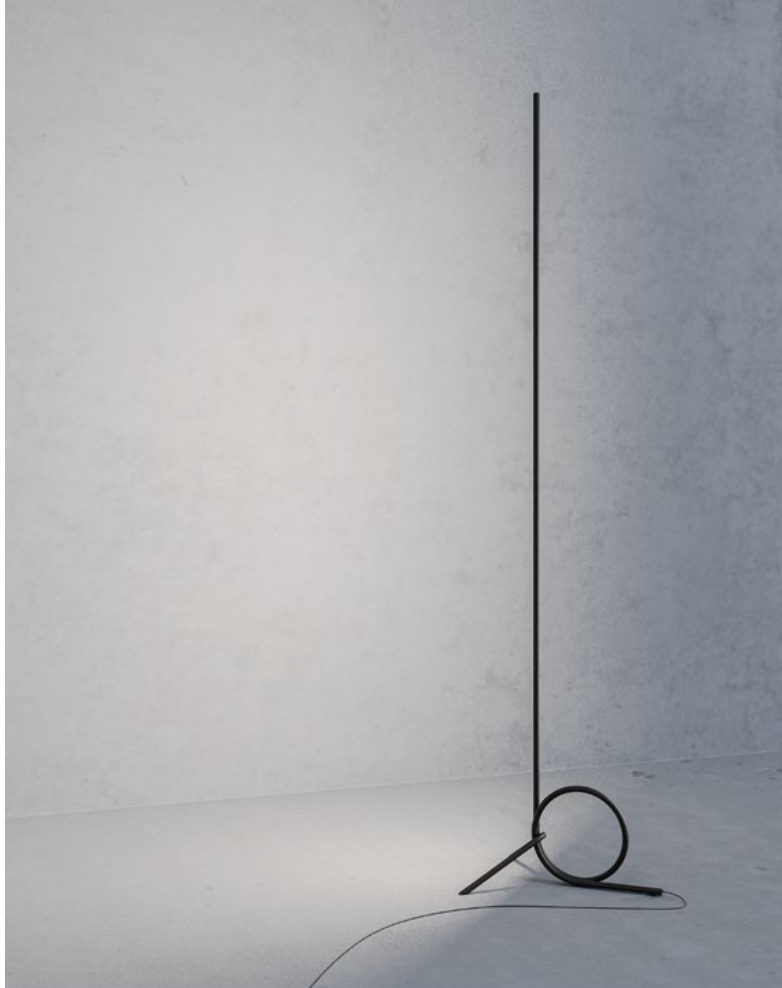

Spring floor, Deep Black



**In its floor version, Spring features a LED strip that projects light in a linear way into the surrounding space. Spring's base can be directed during installation, allowing the user to position the output cable towards the wall or in the diametrically opposite direction. Spring, available in one size (180 cm) in the Deep Black finish, is equipped with a foot dimmer that allows the light intensity to be adjusted at will. As far as the LED strip is concerned, it will be available in a 2700K version.**

# Spring

Nella versione da terra, Spring è dotata di uno strip led che proietta la luce in modo lineare nello spazio circostante. La base può essere direzionata in fase di montaggio: ciò consente all'utente di posizionare il cavo in uscita verso la parete oppure nella direzione diametralmente opposta. Spring, disponibile in un'unica dimensione (180 cm) nella finitura Deep Black, è dotata di dimmer a piede che permette di regolarne a piacere l'intensità luminosa, per quanto riguarda lo strip LED, è disponibile nella versione 2700 K.



# Spring





# Spring

The wall mounted lamp is available in two different versions: large, with an arm over 2 meters long, and medium, with a shaft measuring over 1 meter. Conversely, in the ceiling mounted version the light point is over 1 meter away from the ceiling. Available in a single Deep Black finish, Spring fully meets the needs of the user, who can direct the light at will by orienting the lampshade, equipped with an E27 bulb socket.



Nella versione a parete, l'elemento tubolare del braccio in metallo si piega su sé stesso, creando così un cerchio che ricorda una molla. È disponibile in due differenti dimensioni: mentre la large è dotata di un braccio lungo più di 2 metri, la medium ha un'asta che misura oltre un metro. Nella versione a soffitto invece, il decentramento del punto luce dista oltre un metro. Spring incontra pienamente le esigenze dell'utente che può direzionare la luce orientando a piacimento il paralume dotato di una sorgente luminosa che prevede una lampadina con attacco E27.





# Spring



Spring, Deep Black



# Spring

Wall

## Spring Medium

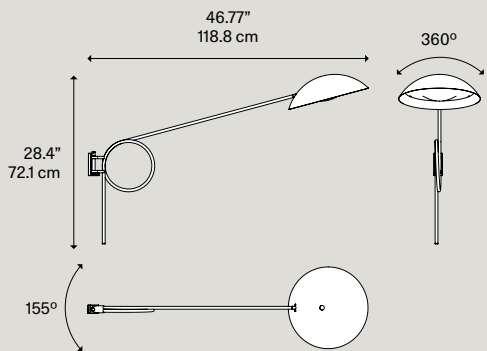

Light source  
Sorgente luminosa

Structure  
Montatura

Diffuser  
Diffusore

Code  
Codice

N. America  
Code

E27 LED  
1 X 25W



Deep Black

Deep Black

51451 2000

—

E26 LED  
1 X 25W



Deep Black

Deep Black

51451 2000U

BULBS not included  
LAMPADINE non incluse

Net Weight/ Peso Netto: 2,5 kg

Pack/ Colli: 1

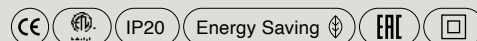

Wall

## Spring Large

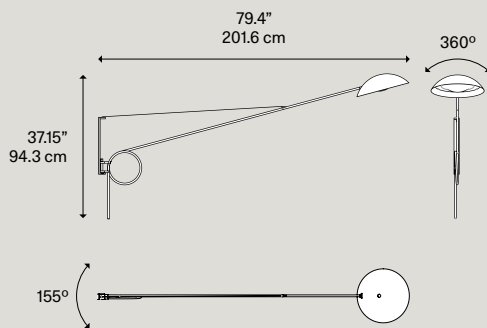

Light source  
Sorgente luminosa

Structure  
Montatura

Diffuser  
Diffusore

Code  
Codice

N. America  
Code

E27 LED  
1 X 25W



Deep Black

Deep Black

51452 2000

—

E26 LED  
1 X 25W



Deep Black

Deep Black

51452 2000U

BULBS not included  
LAMPADINE non incluse

Net Weight/ Peso Netto: 3,7 kg

Pack/ Colli: 1

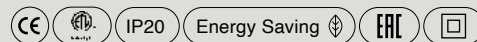

Spring wall Large



Spring wall Medium



Spring ceiling



Spring floor

Ceiling

## Spring Ceiling

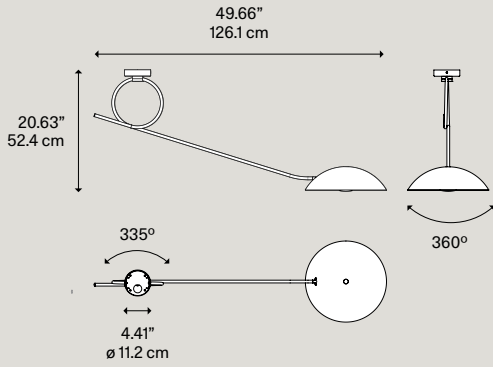

Light source Sorgente luminosa	Structure Montatura	Diffuser Diffusore	Code Codice	N. America Code
E27 LED 1 X 25W	Deep Black	Deep Black	51431 2000	—
E26 LED 1 X 25W	Deep Black	Deep Black	—	51431 2000U
BULBS not included LAMPADINE non incluse				

Net Weight/ Peso Netto: 2,3 kg

Pack/ Colli: 1

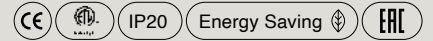

Floor

## Spring New

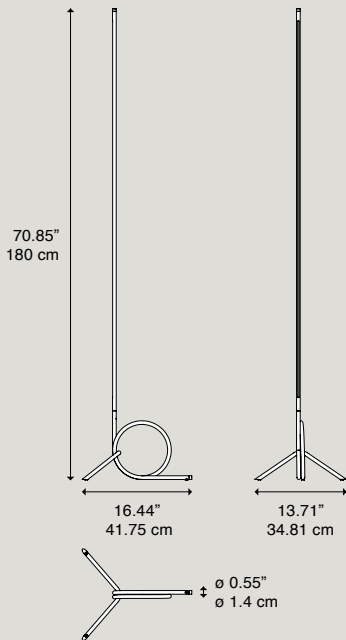

Light source Sorgente luminosa	Structure Montatura	Diffuser Diffusore	Code Codice	N. America Code
LED 2700K 30.5 W / 3050 lm CRI 95 MacAdam 3-Step	Deep Black	Deep Black	51470 2027	51470 2027U
LED and DRIVER included Dimmer on the cord included				
LED e DRIVER inclusi Dimmer nel filo incluso				

Net Weight / Peso Netto: 2 kg

Pack / Colli: 1



Its origin is “underground”: Cage is inspired by the lamps used by miners and workers, protected by a metal cage which here becomes a decorative element and gives the lamp its name.

La sua origine è “underground”: Cage si ispira alle lampade dei minatori e degli operai, protette da una gabbia metallica, che diventa qui elemento decorativo e dà il nome alla lampada.

# Cage



◀ Cage Large, White/White

Cage Large, Bronze/Black  
Cage Small, White/White ▶



◀ Cage Small, composition of 24 lights on single canopies



The contrast between the delicacy of the blown glass of the elegant glossy diffuser and the hardness of the steel of the outer cage with its irregular structure makes Cage unique and gives it an elegantly vintage touch. The diffuser is available in two colors, White and Bronze, which can be combined as desired with the metal cage in White or Black finishes.

In the bronze version, the light source gives it a double soul: when switched off, the shiny surface of the glass reflects the geometries of the cage; when switched on, the reflection disappears and the color of the glass becomes warmer. Cage Large, with a diameter of 46 cm, is a suspension lamp of great effect. The Small version has a diameter of 27,5 cm.

# Cage

Il contrasto fra la delicatezza del vetro soffiato dell'elegante diffusore lucido e la durezza dell'acciaio della gabbia esterna dalla struttura irregolare rende Cage inconfondibile e le dona un tocco elegantemente vintage. Il diffusore è disponibile in due colori, White e Bronze, che possono essere combinati a piacere con la gabbia metallica nelle finiture White oppure Black. Nella versione Bronze, la fonte luminosa le regala una doppia anima: da spenta la superficie lucida del vetro riflette le geometrie della gabbia, da accesa il riflesso scompare e il colore del vetro diventa più caldo. Cage Large, con un diametro di 46 cm, è una lampada a sospensione di grande effetto mentre la versione Small misura 27,5 cm.

Cage Large, Black/Bronze







Cage Large, Bronze/Black  
Cage Small, White/White

Cage Small, White/Black



# Cage

Suspension lamp

## Cage Small

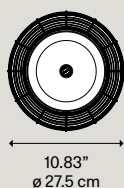
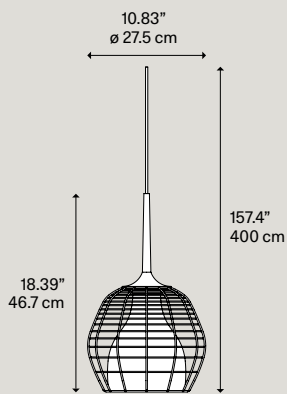

Light source  
Sorgente luminosa

Structure  
Montatura

Diffuser  
Diffusore

Code  
Codice

N. America  
Code

LED E27  
1 max 15W



White



White

50110 1600

—



Bronze

50110 3700

—

Black



White

50110 1700

—



Bronze

50110 3600

—

LED  
Medium Base  
1 max 15W



White



White

50110 1600U



Bronze

50110 3700U



White

50110 1700U



Bronze

50110 3600U

BULBS not included  
LAMPADINE non incluse

Net Weight/ Peso Netto: 2.35 kg

Pack/ Colli: 2

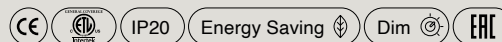

Suspension lamps must be installed on a single canopy ▶ pages 136 - 137  
Le lampade a sospensione devono essere installate su rosone singolo ▶ pagine 136 - 137



**Materials** Vacuum metallized blown glass diffuser  
Metal cage  
Diffusore in vetro soffiato metallizzato sottovuoto  
Gabbia in metallo

**Light** Suspension lamp providing diffuse and downward directed light. Commercial light bulb socket  
Lampada a sospensione a luce diffusa e diretta verso il basso. Predisposizione lampadina commerciale.

Suspension lamp

# Cage Large

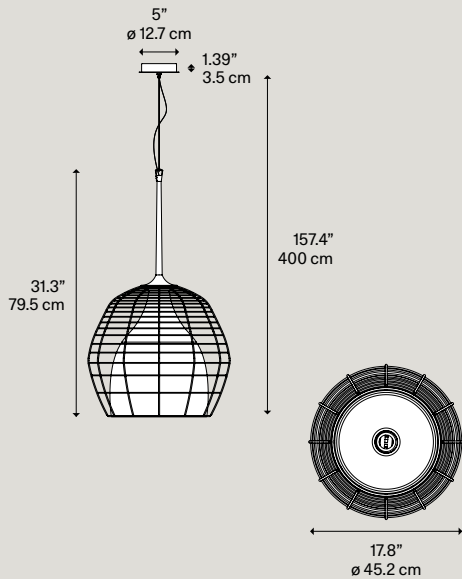

Net Weight/ Peso Netto: 5.4 kg

Pack/ Colli: 2

Light source Sorgente luminosa	Structure Montatura	Diffuser Diffusore	Code Codice	N. America Code
LED E27 1 max 25W	White	White	50120 1600	—
		Bronze	50120 3700	—
	Black	White	50120 1700	—
		Bronze	50120 3600	—
LED Medium Base 1 max 25W	White	White	—	50120 1600U
		Bronze	—	50120 3700U
	Black	White	—	50120 1700U
		Bronze	—	50120 3600U

BULBS not included  
LAMPADINE non include

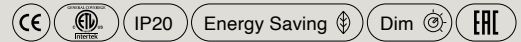

**Colors**      White/ White                      Bronze/ White  
                     White/ Black                              Bronze/ Black



# Flask

Inspired by the unique shapes of glass bottles used in science labs, Flask features a metallic surface that reveals its glass nature when lit. Its shape recalls an object with an industrial flavor in which the marked contrast between the lightness of blown glass and the material quality of the metal finish are combined. The piece is further enhanced by the contrast between the matt metallic outer and the glossy inner surface that glows and dances with the light.

Ispirata alle singolari forme delle bottiglie di vetro utilizzate nei laboratori scientifici, Flask è caratterizzata da una superficie metallica che, una volta accesa, rivela la sua vera natura di vetro. La sua forma ricorda un oggetto dal sapore industriale in cui il forte contrasto visivo tra la leggerezza del vetro soffiato e la matericità della finitura metallica convivono. La lampada è ulteriormente valorizzata dalla contrapposizione tra la superficie esterna metallizzata opaca e l'interno lucido che, quando la lampada è accesa, si illumina con una inaspettata danza di luce.





Flask A, B, C  
Metallic Black



## Flask

When the lamp is lit, Flask reveals a light source that floats in the glass body with an inner glossy surface that glows to create a daring visual effect. The neck of the lamp has been designed to remain dark at all times, thus enhancing the silhouette of the piece and its industrial surface. At the top end, a black silicone cap with the DIESEL logo seals the lamp and gives it an extremely industrial touch. Available in three shapes and with two finishes – Metallic Black and Mineral Sand – that evoke industrial worlds.

Accesa, la sospensione Flask rivela una sorgente luminosa che sembra fluttuare nel corpo di vetro, illumina la superficie interna lucida e crea un audace effetto visivo. Il collo della lampada è stato invece progettato per rimanere sempre spento, valorizzando così la linea del prodotto e la sua superficie industriale. All'estremità superiore, un tappo in silicone nero con logo DIESEL sigilla la lampada e le conferisce un tocco estremamente industriale. Con tre forme disponibili e due finiture che evocano mondi industriali - Metallic Black e Mineral Sand.

Flask B, Metallic Black



# Flask



Flask A,B,C, compositions on single canopies.  
Metallic Black, Mineral Sand



# Flask



Flask A,B,C  
Metallic Black, Mineral Sand



# Flask

Suspension lamp

## Flask A

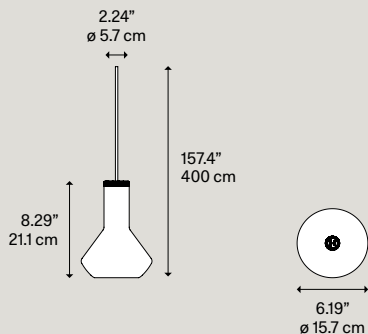

Light source  
Sorgente luminosa

Structure  
Montatura

Diffuser  
Diffusore

Code  
Codice

N. America  
Code

LED E27  
1 max 15W



—

Metallic Black

50321 2100

—

Mineral Sand

50321 5200

—

LED  
Medium Base  
1 max 15W



—

Metallic Black

—

50321 2100U

Mineral Sand

—

50321 5200U

BULBS not included  
LAMPADINE non include

Net Weight/ Peso Netto: 0.44 kg

Pack/ Colli: 2

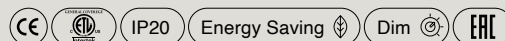

Suspension lamps must be installed on a single canopy ► pages 136 - 137  
Le lampade a sospensione devono essere installate su rosone singolo ► pagine 136 - 137

Suspension lamp

## Flask B

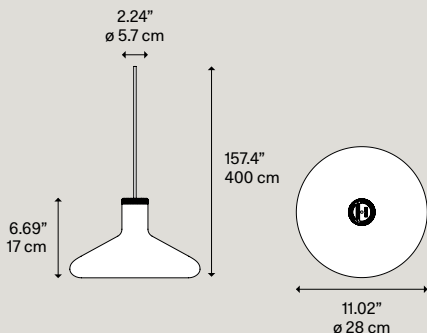

Light source  
Sorgente luminosa

Structure  
Montatura

Diffuser  
Diffusore

Code  
Codice

N. America  
Code

LED E27  
1 max 15W



—

Metallic Black

50322 2100

—

Mineral Sand

50322 5200

—

LED  
Medium Base  
1 max 15W



—

Metallic Black

—

50322 2100U

Mineral Sand

—

50322 5200U

BULBS not included  
LAMPADINE non include

Net Weight/ Peso Netto: 0.95 kg

Pack/ Colli: 2

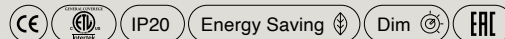

Suspension lamps must be installed on a single canopy ► pages 136 - 137  
Le lampade a sospensione devono essere installate su rosone singolo ► pagine 136 - 137

**Materials** Vacuum metallized blown glass diffuser  
Diffusore in vetro soffiato metallizzato sottovuoto

**Light** Suspension lamp providing direct light  
commercial light bulb socket  
Lampada a sospensione a luce diretta  
Predisposizione lampadine commerciali

**Colors** Metallic Black  
Mineral Sand

Suspension lamp

# Flask C

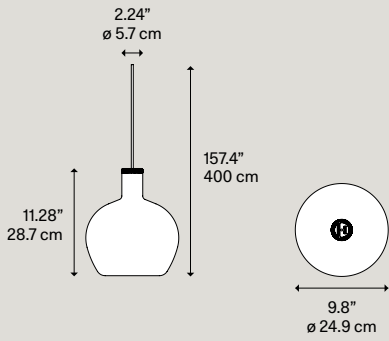

Light source Sorgente luminosa	Structure Montatura	Diffuser Diffusore	Code Codice	N. America Code
LED E27 1 max 15W	—	Metallic Black	<b>50323 2100</b>	—
		Mineral Sand	<b>50323 5200</b>	—
LED Medium Base 1 max 15W	—	Metallic Black	—	<b>50323 2100U</b>
		Mineral Sand	—	<b>50323 5200U</b>
BULBS not included LAMPADINE non incluse				

Net Weight/ Peso Netto: 0.75 kg

Pack/ Colli: 2

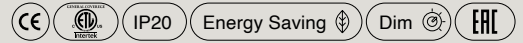

Suspension lamps must be installed on a single canopy ► pages 136 - 137  
Le lampade a sospensione devono essere installate su rosone singolo ► pagine 136 - 137



Flask, black cap with the Diesel logo

# Fork



**Fork is a steel “fork” holding a diffuser inspired by casual fashion, camping tents and an informal and gritty lifestyle. An always current concept interpreted in table, floor and suspension versions, for every environment and moment of everyday life.**

**Fork è una “forchetta” di acciaio su cui posa un diffusore ispirato alla moda casual, alle tende da campeggio, a uno stile di vita informale e grintoso. Un concetto sempre attuale declinato nelle versioni da tavolo, terra e sospensione, per ogni ambiente e momento della vita quotidiana.**





Fork table, Ivory/Gray and Anthracite/Ivory



# Fork

Just like when you turn on a lamp inside a camping tent, the light inside the diffuser highlights the patchwork structure and enhances the texture of the canvas with visible stitching as in jeans. The linen cotton diffuser, available in Ivory and Gray, creates a warm and soft lighting effect. 360° adjustable thanks to the gunmetal colored brass eyelets in strong material contrast with the softness of the fabric, the diffuser allows the light beam to be directed at will.

Come quando si accende una lampada dentro a una tenda da campeggio, la luce all'interno del diffusore evidenzia la struttura a patchwork ed esalta la texture della tela con le cuciture a vista come nei jeans. Il diffusore in cotone-lino, disponibile in Ivory e Gray, crea un effetto luminoso caldo e soffuso. Orientabile a 360° grazie agli occhielli in ottone color canna di fucile in forte contrasto materico con la morbidezza del tessuto, il diffusore permette di dirigere il fascio di luce a piacere.

## FLOOR FORK

The metal structure supporting the diffuser is available in two colors, Ivory or Anthracite. The rod, with its characteristic tilt, rotates on the base, allowing the light to be projected in complete freedom.

La struttura in metallo che regge il diffusore è disponibile in color Ivory o Anthracite. L'asta, con l'inclinazione che da sempre la caratterizza, gira sulla base e permette di condividere il fascio di luce in assoluta libertà.

## TABLE FORK

The metal structure proposes the same lines, colors and functions of the floor lamp but in the Small version, perfect for any space.

La struttura in metallo ripropone linee, colori e funzioni della lampada da terra ma in versione Small, perfetta per qualunque spazio.

## SUSPENSION FORK

Available in the Large or Small version, Fork is a single suspension lamp with great character thanks to the adjustable diffuser suspended from a supporting cable.

Disponibile nella versione Large o Small, Fork è una sospensione singola di grande carattere grazie al diffusore orientabile sospeso ad un cavo portante.

# Fork



Fork table, floor, suspension  
Anthracite/Ivory



# Fork

Suspension lamp

## Fork Small

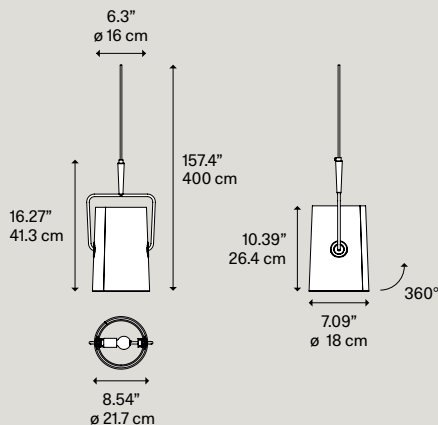

Light source  
Sorgente luminosa

Structure  
Montatura

Diffuser  
Diffusore

Code  
Codice

N. America  
Code

LED E14  
1 max 15W  
(L Max 90 mm)



Ivory

Ivory

50510 5400

—

Gray

50510 2600

—

Anthracite

Ivory

50510 5300

—

Gray

50510 2500

—

LED  
Candelabra  
Base  
1 max 15W  
(L Max 3.54")



Ivory

Ivory

50510 5400U

Gray

50510 2600U

Anthracite

Ivory

50510 5300U

Gray

50510 2500U

BULBS not included  
LAMPADINE non incluse

Net Weight/ Peso Netto: 0.8 kg

Pack/ Colli: 2

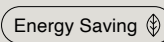

Suspension lamps must be installed on a single canopy ► pages 136 - 137  
Le lampade a sospensione devono essere installate su rosone singolo ► pagine 136 - 137



**Materials** Cotton-linen diffuser  
Metal structure  
Diffusore in lino-cotone  
Struttura in metallo

### Light

Lamp providing direct and diffused light  
Two commercial light bulb sockets in the Large diffuser and one light bulb socket in the Small diffuser  
Lampada a luce diretta e diffusa  
Predisposizione per due lampadine commerciali nel diffusore Large e una lampadina nel diffusore Small

Suspension lamp

# Fork Large

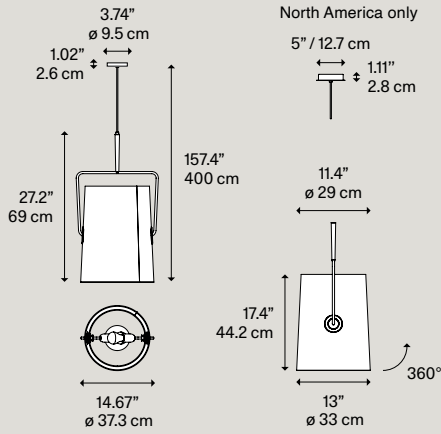

Light source  
Sorgente luminosa

Structure  
Montatura

Diffuser  
Diffusore

Code  
Codice

N. America  
Code

LED E27  
2 max 25W  
(Max Ø 65 mm)



Ivory

Ivory

50520 5400

—

Gray

50520 2600

—

Anthracite

Ivory

50520 5300

—

Gray

50520 2500

—

Ivory

Ivory

50520 5400U

Gray

50520 2600U



LED  
Medium Base  
2 max 25W  
(Max Ø 2.56")

Anthracite

Ivory

50520 5300U

Gray

50520 2500U

BULBS not included  
LAMPADINE non incluse

Net Weight/ Peso Netto: 1.92 kg

Pack/ Colli: 2

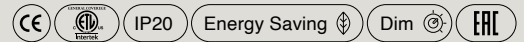

Fork Small, Ivory/Ivory and Anthracite/Gray  
Fork Large, Anthracite/Ivory



Colors

Ivory / Ivory

Gray / Ivory

Ivory / Anthracite

Gray / Anthracite

# Fork

Floor

## Fork

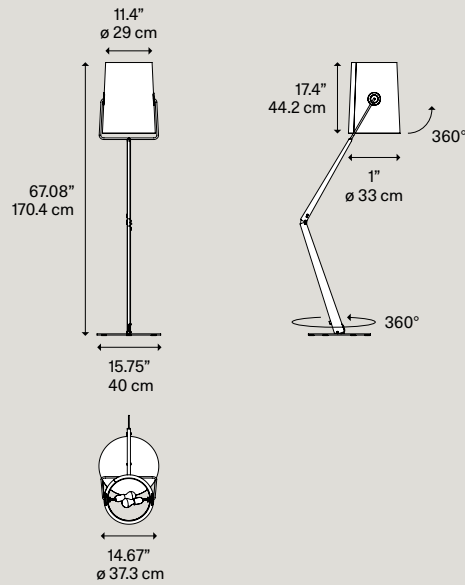

Light source  
Sorgente luminosa

Structure  
Montatura

Diffuser  
Diffusore

Code  
Codice

N. America  
Code

LED E27  
2 max 25W  
(Max Ø 65 mm)



Ivory

Ivory

50570 5400

—

Gray

50570 2600

—

Anthracite

Ivory

50570 5300

—

Gray

50570 2500

—

LED  
Medium Base  
2 max 25W  
(Max Ø 2.56")



Ivory

Ivory

50570 5400U

Gray

50570 2600U

Anthracite

Ivory

50570 5300U

Gray

50570 2500U

BULBS not included  
Dimmer on the cord  
included

LAMPADINE non include  
Dimmer nel filo incluso

Net Weight/ Peso Netto: 11.82 kg

Pack/ Colli: 2



**Materials** Cotton-linen diffuser  
Metal structure  
Diffusore in lino-cotone  
Struttura in metallo

**Colors** Ivory / Ivory      Gray / Ivory  
Ivory / Anthracite      Gray / Anthracite

### Light

Lamp providing direct and diffused light  
Two commercial light bulb sockets in the Large diffuser  
and one light bulb socket in the Small diffuser  
Lampada a luce diretta e diffusa  
Predisposizione per due lampadine commerciale nel  
diffusore Large e una lampadina nel diffusore Small

Table

# Fork

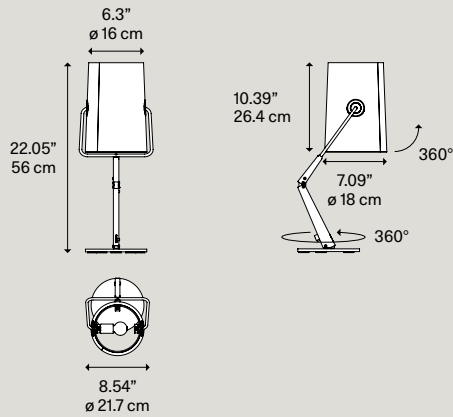

Light source Sorgente luminosa	Structure Montatura	Diffuser Diffusore	Code Codice	N. America Code
LED E14 1 max 15W (L Max 90 mm)	Ivory	Ivory	50580 5400	—
		Gray	50580 2600	—
	Anthracite	Ivory	50580 5300	—
		Gray	50580 2500	—
LED Candelabra Base 1 max 15W (L Max 3.54")	Ivory	Ivory	—	50580 5400U
		Gray	—	50580 2600U
	Anthracite	Ivory	—	50580 5300U
		Gray	—	50580 2500U

BULBS not included  
LAMPADINE non include

Net Weight/ Peso Netto: 2.85 kg

Pack/ Colli: 2



**Materials** Cotton-linen diffuser  
Metal structure  
Diffusore in lino-cotone  
Struttura in metallo

**Colors** Ivory / Ivory      Gray / Ivory  
Ivory / Anthracite      Gray / Anthracite

**Light** Lamp providing direct and diffused light  
Two commercial light bulb sockets in the Large diffuser  
and one light bulb socket in the Small diffuser  
Lampada a luce diretta e diffusa  
Predisposizione per due lampadine commerciali nel  
diffusore Large e una lampadina nel diffusore Small





# Gask

Gask is a small suspension lamp with a big presence. It looks like it came out of a 1920s emporium or a warehouse for work tools, but also recalls ziggurats, the sacred terraced pyramids of ancient Mesopotamia.

Gask è una piccola lampada a sospensione dalla grande presenza. Sembra uscita da un emporio degli anni Venti o da un magazzino di strumenti di lavoro, ma ricorda anche le ziggurat, sacre piramidi a terrazze dell'antica Mesopotamia.



Gask, Army Green

# Gask

Gask, compositions on single canopies,  
Army Green, Transparent



Gask, Transparent



Gask è un mix perfetto di materiali in apparente contrasto sensoriale - vetro, acciaio, ottone - che creano una miscela ideale. La montatura in acciaio ha una finitura nera opaca, ruvida e materica dal sapore fortemente industriale, ed è unita al diffusore con bulloni a vista in ottone. Il delicato diffusore in vetro soffiato, nelle finiture Transparent o Army Green, dichiara deliberatamente la presenza della fonte luminosa al suo interno.

**Gask is a perfect mix of materials in apparent sensory contrast – glass, steel, brass – which create an ideal blend. The steel mount has a Black matt finish, rough and textured with a strong industrial flavor, and is joined to the diffuser with visible brass bolts. The subtle diffuser in blown glass, in Transparent or Army Green finishes, intentionally declares the presence of the light source inside.**

# Gask

Suspension lamp

## Gask

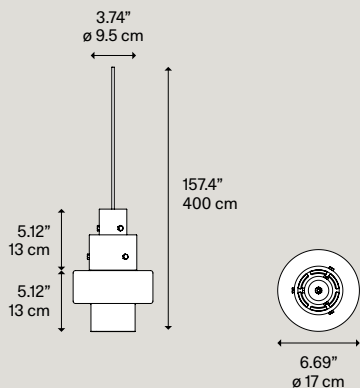

Light source  
Sorgente luminosa

Structure  
Montatura

Diffuser  
Diffusore

Code  
Codice

N. America  
Code

LED E14  
1 max 15W

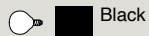

Transparent

50620 0000

—

Army Green

50620 7100

—

LED  
Candelabra  
Base  
1 max 15W



Transparent

—

50620 0000U

Army Green

—

50620 7100U

BULBS not included  
LAMPADINE non include

Net Weight/ Peso Netto: 0.99 kg

Pack/ Colli: 2

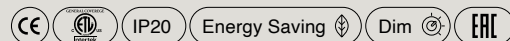

Suspension lamps must be installed on a single canopy ► pages 136 - 137  
Le lampade a sospensione devono essere installate su rosone singolo ► pagine 136 - 137



**Materials** Blown glass diffuser  
Metal structure  
Diffusore in vetro soffiato  
Struttura in metallo

**Colors** Transparent  
Army Green

**Light** Suspension lamp providing direct and diffused light  
commercial light bulb socket  
Lampada a luce diretta e diffusa  
Predisposizione lampadina commerciale

Gask, Transparent and Army Green



# Glass Drop



**Like a drop of incandescent material, Glass Drop seems to represent the magical and elusive nature of blown glass at the instant it is both fluid and solid, just before it takes shape.**

**Come una goccia di materiale incandescente, Glass Drop sembra rappresentare la magica e sfuggente natura del vetro soffiato nell'istante in cui è al tempo stesso fluido e solido, poco prima di prendere forma.**







Glass Drop, White



Nella versione Chrome, ha una superficie che da spenta riflette come uno specchio, mentre da accesa sembra che la luce sciogla il metallo rivelando il proprio colore: una lampada che cambia personalità con un semplice tocco sull'interruttore. Glass Drop è disponibile anche in una candida versione White che offre un'estrema versatilità di ambientazione.

## Glass Drop

In the Chrome version, its surface reflects like a mirror when turned off, while when turned on the light seems to dissolve the metal revealing its color: a lamp that changes personality with a simple touch of the switch. Glass Drop is also available in a pure White version that offers extreme versatility of setting.

◀ Glass Drop, Chrome

# Glass Drop





# Glass Drop

Suspension lamp

## Glass Drop

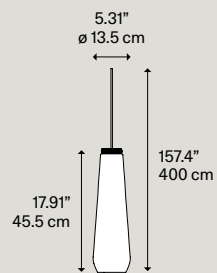

Light source  
Sorgente luminosa

Structure  
Montatura

Diffuser  
Diffusore

Code  
Codice

N. America  
Code

LED E27  
1 max 25W



—

White

50420 1200

—

Chrome

50420 4000

—

LED  
Medium Base  
1 max 15W



—

White

50420 1200U

Chrome

50420 4000U

BULBS not included  
LAMPADINE non incluse

Net Weight/ Peso Netto: 1.77 kg

Pack/ Colli: 2

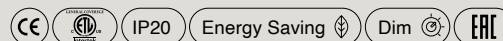

Suspension lamps must be installed on a single canopy ► pages 136 - 137  
Le lampade a sospensione devono essere installate su rosone singolo ► pagine 136 - 137



**Materials** Blown glass diffuser  
Diffusore in vetro soffiato

**Colors** White  
Chrome

**Light** Suspension lamp providing diffused light  
commercial light bulb socket  
Lampada a sospensione a luce diffusa  
Predisposizione lampadine commerciali

Glass Drop,  
White, Chrome





Shapes reminiscent of large factory pipes, dematerialized and lightened by their fabric nature. These are the Pipe lamps, which stand out due to their large size and the warm light diffused over the entire surface.

Forme che ricordano le grandi tubature di una fabbrica, smaterializzate e alleggerite dalla loro natura tessile. Sono le lampade Pipe, che si caratterizzano per le dimensioni importanti e la luce calda diffusa su tutta la superficie.

# Pipe





# Pipe

Pipe was born from Diesel's research in the world of fabrics and is available in bleached raw linen or with printed patterns. The irregular weave transforms into a luminous décor, adding further emotion to the fabric and revolutionizing the traditional lampshade. Available in two sizes, Medium and Large, Pipe is an architectural presence that can be used alone or in groups of several elements, to illuminate, characterize and even define a space.

Pipe Large, White

Pipe nasce dalla ricerca Diesel nell'universo dei tessuti ed è disponibile in lino grezzo sbiancato o con decoro stampato. La trama irregolare si trasforma in un decoro luminoso, aggiungendo ulteriore emozione al tessuto e rivoluzionando il paralume tradizionale. Disponibile in due dimensioni, Medium e Large, Pipe è una presenza architettonica che può essere utilizzata da sola o in gruppi di più elementi, per illuminare, caratterizzare e anche definire uno spazio.

Pipe Medium and Large,  
Black



# Pipe

Floor

## Pipe Medium

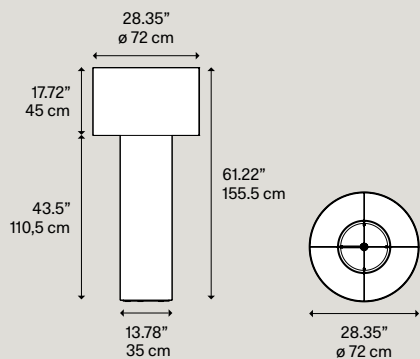

Light source  
Sorgente luminosa

Structure  
Montatura

Diffuser  
Diffusore

Code  
Codice

N. America  
Code

LED E27  
2 max 25W



White

50772 1000

—

Black

50772 2000

—

LED  
Medium Base  
2 max 25W



White

50772 1000U

Black

50772 2000U

BULBS not included  
Dimmer on the cord  
included

LAMPADINE non incluse  
Dimmer nel filo incluso

Net Weight/ Peso Netto: 9 kg

Pack/ Colli: 3



**Materials** Linen diffuser  
Diffusore in lino

**Colors** White  
Black

**Light** Lamp providing diffused light  
Two commercial light bulb sockets  
Lampada a luce diffusa  
Predisposizione per due lampadine commerciali

Floor

# Pipe Large

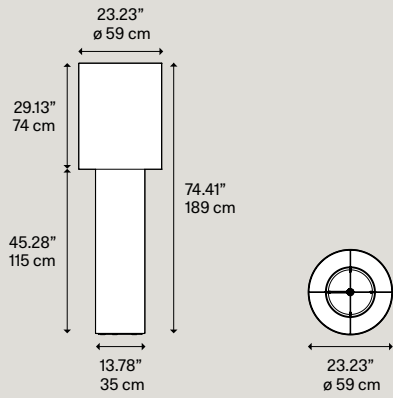

Net Weight/ Peso Netto: 8.5 kg

Pack/ Colli: 3

Light source  
Sorgente luminosa

Structure  
Montatura

Diffuser  
Diffusore

Code  
Codice

N. America  
Code

LED E27  
2 max 25W



White

50773 1000

—

Black

50773 2000

—

LED  
Medium Base  
2 max 25W



White

50773 1000U

Black

50773 2000U

BULBS not included  
Dimmer on the cord  
included

LAMPADINE non incluse  
Dimmer nel filo incluso



Pipe Medium, White

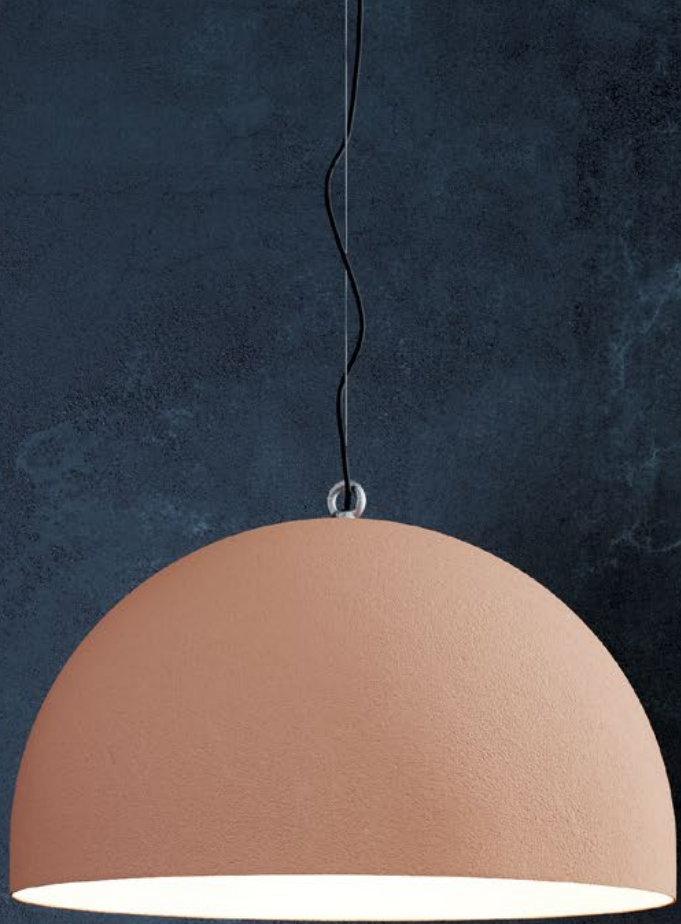

# Urban Concrete

Urban Concrete 60, Pink Dust

Taking inspiration from the bollards found in the urban landscape, Urban Concrete is a lighting piece balancing clean lines and solid surfaces with a dome crowned by a lifting hook.

Ispirata ai dissuasori che emergono dal paesaggio urbano, Urban Concrete è una lampada che coniuga linee pulite e superfici solide in una forma a cupola sormontata da un gancio di sollevamento.



# Urban Concrete

Whilst the spun metal dome evokes a cement block and creates an illusion of heaviness, Urban Concrete is extremely light and flexible. Thanks to the contrast between the three cement finishes – Soft Gray, Tough Gray and Pink Dust – and the pure white of the diffuser's internal surface, Urban Concrete gives a touch of material appeal and sophistication to any interior. Available in four sizes (25, 50, 60, and 80 cm), Urban Concrete is designed for different uses and interiors, both domestic and public. The 25 cm dome is suspended from one single power cable.

Mentre la cupola in metallo tornito richiama un blocco di cemento e crea un'illusione di gravità, Urban Concrete è in realtà una lampada a sospensione molto leggera e duttile. Grazie al contrasto tra le tre finiture in cemento - Soft Gray, Tough Gray e Pink Dust - e il bianco candido della superficie interna del diffusore, Urban Concrete conferisce un tocco di matericità e raffinatezza a qualsiasi interno.

Disponibile in quattro dimensioni (25, 50, 60 e 80 cm), Urban Concrete è pensata per diversi usi e tipologie di interni domestici e pubblici. La cupola da 25 cm è sospesa ad un singolo cavo portante con un gioco di equilibri tra solidità e semplicità.







# Urban Concrete



Urban Concrete 80, Soft Gray  
Urban Concrete 25, compositions of 3 lights on single canopies,  
Pink Dust, Soft Gray, Tough Gray



# Urban Concrete





# Urban Concrete

Suspension lamp

## Urban Concrete 25

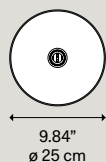
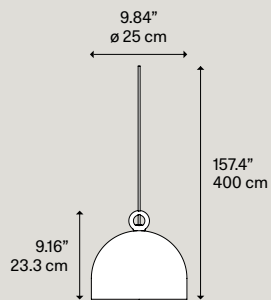

Light source  
Sorgente luminosa

Inside diffuser  
Diffusore interno

Outside diffuser  
Diffusore esterno

Code  
Codice

N. America  
Code

LED E27  
1 max 15W



White

LED  
Medium Base  
1 max 15W



White

BULBS not included  
LAMPADINE non incluse

Pink Dust

50210 6100

—

Tough Gray

50210 3100

—

Soft Gray

50210 3000

—

Pink Dust

—

50210 6100U

Tough Gray

—

50210 3100U

Soft Gray

—

50210 3000U

Net Weight/ Peso Netto: 1.45 kg

Pack/ Colli: 1

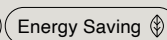

Suspension lamps must be installed on a single canopy ► pages 136 - 137  
Le lampade a sospensione devono essere installate su rosone singolo ► pagine 136 - 137



**Materials** Metal diffuser  
Diffusore in metallo

**Colors** Pink Dust  
Tough Gray  
Soft Gray

**Light** Suspension lamp providing direct light  
Lampada a sospensione a luce diretta

Urban Concrete 25,  
Pink Dust, Soft Gray, Tough Gray



# Urban Concrete

Suspension lamp

## Urban Concrete 50

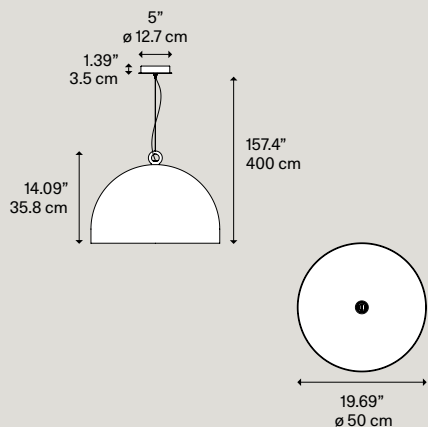

Light source  
Sorgente luminosa

Inside diffuser  
Diffusore interno

Outside diffuser  
Diffusore esterno

Code  
Codice

N. America  
Code

LED E27 G95  
1 max 25W



White

Pink Dust

50221 6100

—

Tough Gray

50221 3100

—

Soft Gray

50221 3000

—

LED G30  
Medium Base  
1 max 25W



White

Pink Dust

—

50221 6100U

Tough Gray

—

50221 3100U

Soft Gray

—

50221 3000U

BULBS not included  
LAMPADINE non incluse

Net Weight/ Peso Netto: 5.5 kg

Pack/ Colli: 1

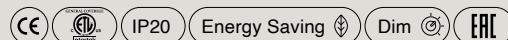

Urban Concrete 50



Urban Concrete 60



Urban Concrete 80

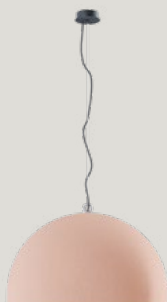

Suspension lamp

# Urban Concrete 60

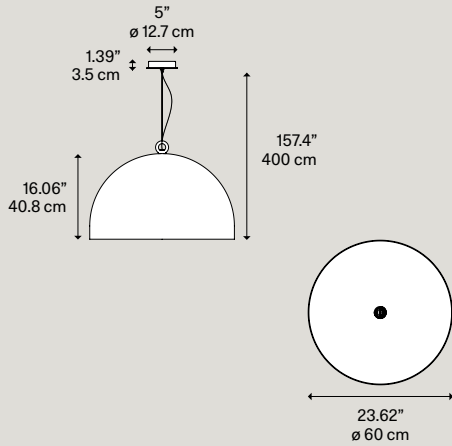

Light source  
Sorgente luminosa

Inside diffuser  
Diffusore interno

Outside diffuser  
Diffusore esterno

Code  
Codice

N. America  
Code

LED E27 G95  
1 max 25W



White



Pink Dust

**50222 6100**

\_\_\_



Tough Gray

**50222 3100**

\_\_\_



Soft Gray

**50222 3000**

\_\_\_

LED G30  
Medium Base  
1 max 25W



White



Pink Dust

**50222 6100U**



Tough Gray

**50222 3100U**



Soft Gray

**50222 3000U**

BULBS not included  
LAMPADINE non include

Net Weight/ Peso Netto: 9 kg

Pack/ Colli: 1

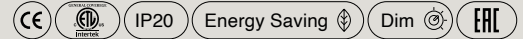

Suspension lamp

# Urban Concrete 80

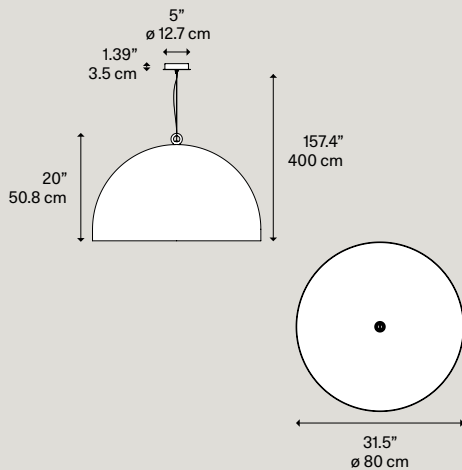

Light source  
Sorgente luminosa

Inside diffuser  
Diffusore interno

Outside diffuser  
Diffusore esterno

Code  
Codice

N. America  
Code

LED E27 G95  
1 max 25W



White



Pink Dust

**50223 6100**

\_\_\_



Tough Gray

**50223 3100**

\_\_\_



Soft Gray

**50223 3000**

\_\_\_

LED G30  
Medium Base  
1 max 25W



White



Pink Dust

**50223 6100U**



Tough Gray

**50223 3100U**



Soft Gray

**50223 3000U**

BULBS not included  
LAMPADINE non include

Net Weight/ Peso Netto: 15.5 kg

Pack/ Colli: 1

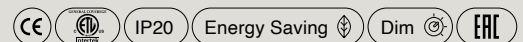



An extremely graphic lamp, Vinyl is made up of a metal plate with a circular engraved texture reminiscent of a music record, emulating sound vibrations whilst dividing the light in a captivating manner to the human eye.

Lampada estremamente grafica, Vinyl è formata da una superficie metallica con un motivo circolare inciso simile ad un disco in vinile che sembra emulare le vibrazioni sonore mentre scompone la luce in modo accattivante all'occhio umano.

# Vinyl



Vinyl Small, Large

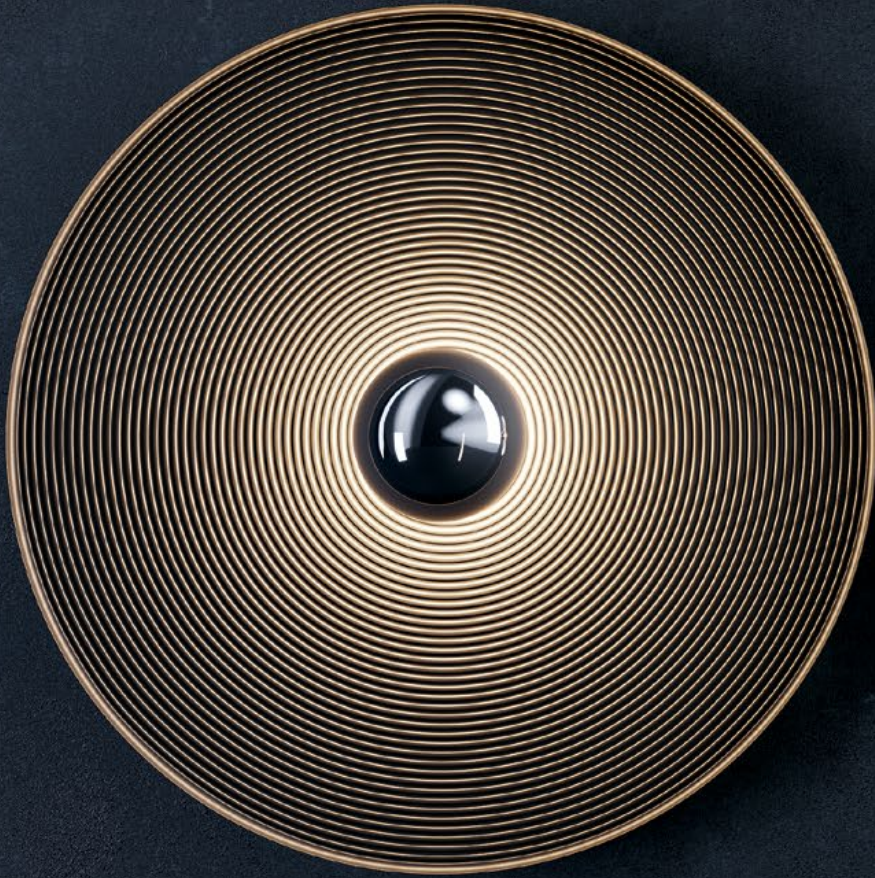

# Vinyl

Vinyl is a versatile, spun metal ceiling and wall lamp, but it is also perfect as a suspension lamp. It is available in two sizes, 60 and 32 cm, and two finishes: Silver and Deep Black. For wall and ceiling versions it is recommended to use shielded light bulbs for an indirect, grazing light effect on the surface, which will seem to vibrate. Its dynamic design makes this decorative lamp perfect for public spaces. Spin the vinyl and enjoy the light!

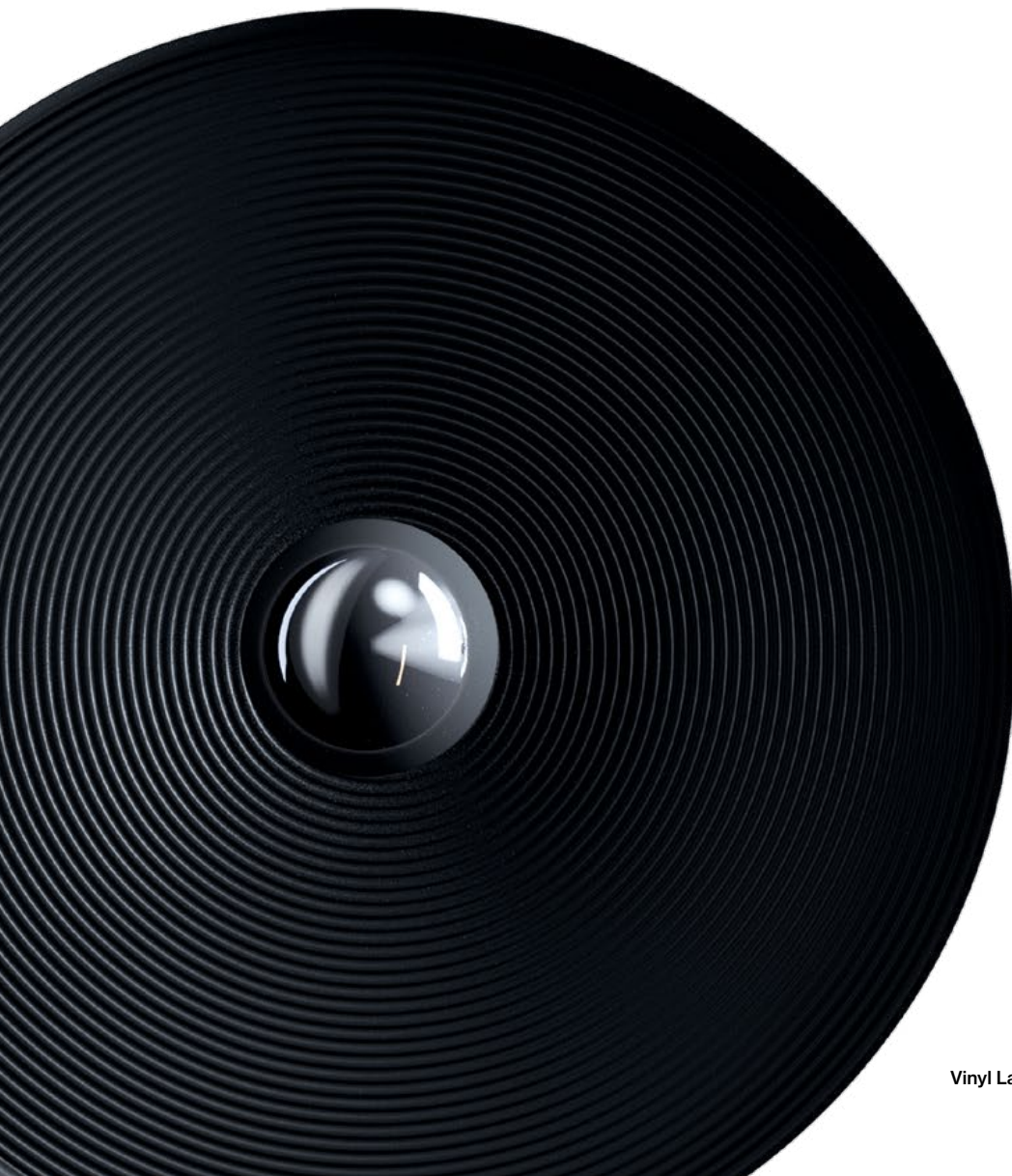

Vinyl Large wall, Deep Black



**Vinyl è una versatile lampada da soffitto e da parete in metallo tornito, perfetta anche come elemento a sospensione. È disponibile in due dimensioni, 60 e 32 cm di diametro, e due finiture: Silver e Deep Black. Per le varianti a parete e soffitto si consiglia l'utilizzo di lampadine a calotta schermata per un effetto di luce indiretta e radente alla superficie, che sembrerà vibrare. Il suo segno dinamico rende questa lampada decorativa perfetta per gli spazi pubblici. Fate girare il vinile e godetevi la luce!**

# Vinyl

Vinyl ceiling and suspension, Deep Black, Silver





# Vinyl



Vinyl Small and Large,  
wall and suspension, Deep Black, Silver





# Vinyl

Suspension lamp

## Vinyl Small

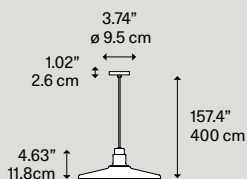

North America only

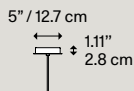

12.6"  
ø 32 cm

Light source  
Sorgente luminosa

Structure  
Montatura

Diffuser  
Diffusore

Code  
Codice

N. America  
Code

LED E27  
1 max 25W



Black

Silver

50821 4100

—

Deep Black

50821 2900

—

LED  
Medium Base  
1 max 25W



Black

Silver

50821 4100U

Deep Black

50821 2900U

BULBS not included  
LAMPADINE non incluse

Net Weight/ Peso Netto: 1.03 kg

Pack/ Colli: 2



IP20

Energy Saving

Dim

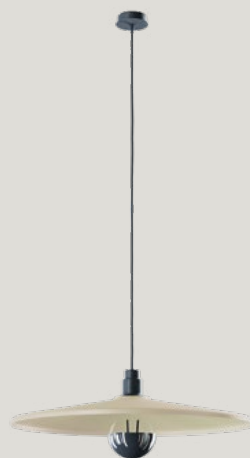
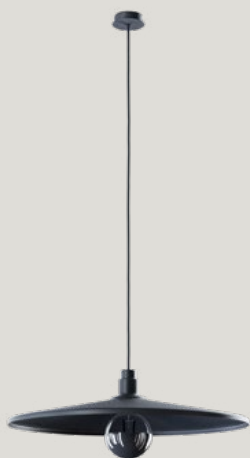

**Materials** Metal diffuser  
Diffusore in metallo

**Colors** Silver  
Deep Black

**Light** Lamp providing shielded / indirect / direct light according to the light bulb  
commercial light bulb socket  
Lampada a luce schermata / indiretta / diretta a seconda della lampadina  
Predisposizione lampadine commerciali

Suspension lamp

# Vinyl Large

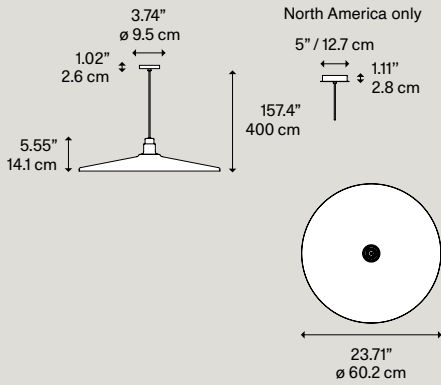

Light source  
Sorgente luminosa

Structure  
Montatura

Diffuser  
Diffusore

Code  
Codice

N. America  
Code

LED E27 G95  
1 max 25W



Black

Silver

50822 4100

—

Deep Black

50822 2900

—

LED G30  
Medium Base  
1 max 25W



Black

Silver

50822 4100U

Deep Black

50822 2900U

BULBS not included  
LAMPADINE non include

Net Weight/ Peso Netto: 2 kg

Pack/ Colli: 2

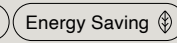

Vinyl Large, Deep Black  
 Vinyl Small, Silver

# Vinyl

Wall/ Ceiling

## Vinyl Large

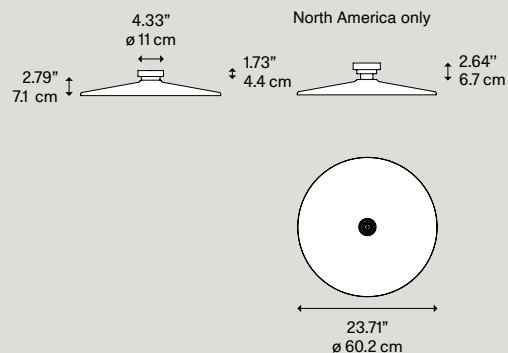

Light source  
Sorgente luminosa

Structure  
Montatura

Diffuser  
Diffusore

Code  
Codice

N. America  
Code

LED E27 G95  
1 max 25W



Black

Silver

50842 4100

—

Deep Black

50842 2900

—

LED G30  
Medium Base  
1 max 25W



Black

Silver

50842 4100U

Deep Black

50842 2900U

BULBS not included  
LAMPADINE non incluse

Net Weight/ Peso Netto: 1.8 kg

Pack/ Colli: 2

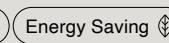

**Materials** Metal diffuser  
Diffusore in metallo

**Colors** Silver  
Deep Black

**Light** Lamp providing shielded / indirect / direct light according to the light bulb  
commercial light bulb socket  
Lampada a luce schermata / indiretta / diretta a seconda della lampadina  
Predisposizione lampadine commerciali

Wall/ Ceiling

# Vinyl Small

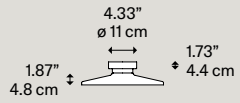

North America only

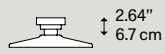

12.6"  
ø 32 cm

Light source  
Sorgente luminosa

Structure  
Montatura

Diffuser  
Diffusore

Code  
Codice

N. America  
Code

LED E27  
1 max 25W



Black

Silver

50841 4100

\_\_\_

Deep Black

50841 2900

\_\_\_

LED  
Medium Base  
1 max 25W



Black

Silver

50841 4100U

Deep Black

50841 2900U

BULBS not included  
LAMPADINE non incluse

Net Weight/ Peso Netto: 0.83 kg

Pack/ Colli: 2

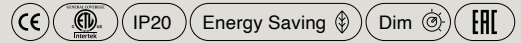

Vinyl Large, Deep Black  
Vinyl Small, Silver

# Single Canopies

## Single Systems



Single Mini

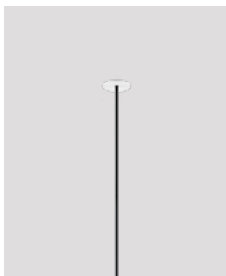

Recessed Micro



Single Standard

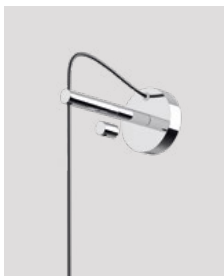

Wall Standard

## Single Canopy

## Single Mini

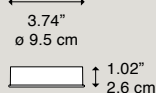

Net weight / Peso netto: 0.13 kg

Pack / Colli: 1

Description Descrizione	Metal structure Struttura in metallo	System Sistema	Code Codice	N. America Code
Single ceiling bracket small size	Matte White – 9010 Bianco Opaco – 9010	Single	<b>R11DL01 1000</b>	—
Rosone per lampada singola versione mini	Matte Black – 9005 Nero Opaco – 9005		<b>R11DL01 2000</b>	—
	Chrome Cromo		<b>R11DL01 4000</b>	—



## Recessed Canopy

## Recessed Micro

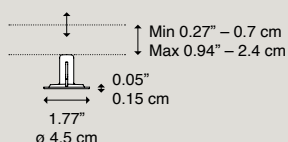
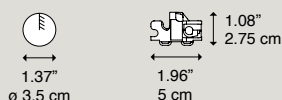

Net weight / Peso netto: 0.025 kg

Pack / Colli: 1

Description Descrizione	Methacrylate structure Struttura in metacrilato	System Sistema	Code Codice	N. America Code
Recessed bracket for single lamp max capacity 3.5 kg	Matte White Bianco Opaco	Recessed	<b>R01DL01 1000</b>	—
Rosone da incasso per lampada singola portata max 3.5 kg	Matte Black Nero Opaco		<b>R01DL01 2000</b>	—
	Chrome Cromo		<b>R01DL01 4000</b>	—



## Single Canopy

## Single Standard

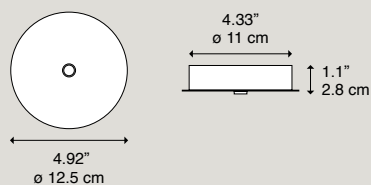

Net weight / Peso netto: 0.4 kg

Pack / Colli: 1

Mounts directly to a 4" Standard J-Box

Description Descrizione	Metal structure Struttura in metallo	System Sistema	Code Codice	N. America Code
Single ceiling bracket standard size	Matte White – 9010 Bianco Opaco – 9010	Single	<b>R03DL01 1000</b>	<b>R03DL01 1000U</b>
Rosone per lampada singola versione standard	Matte Black – 9005 Nero Opaco – 9005		—	<b>R03DL01 2000U</b>
	Chrome Cromo		—	<b>R03DL01 4000U</b>



## Wall Bracket

## Wall Standard

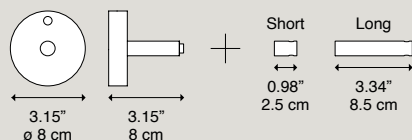

Net weight / Peso netto: 0.8 kg

Pack / Colli: 1

Mounts directly to a 4" Standard J-Box

Description Descrizione	Metal structure Struttura in metallo	System Sistema	Code Codice	N. America Code
Wall bracket for suspension modular system	Chrome Cromo	Wall	<b>R09DL01 4000</b>	<b>R09DL01 4000U</b>
Supporto a parete per sistema modulare a sospensione			—	—



RECESSED MICRO ► Suitable for ceilings up to 0.94" – 2.4 cm thickness. WALL STANDARD ► Both accessories in the two available lengths are supplied in the box with the wall bracket.

RECESSED MICRO ► Adatta per soffitti fino a 0.94" – 2.4 cm di spessore. WALL STANDARD ► Entrambi gli accessori nelle due diverse lunghezze sono inclusi nella confezione con il supporto a parete.